

QM MAX**MQX/QXP Type**

QM *Quick & Mini* **MAX**

New generation high feed mill "QM MAX"

Modular Head
φ16~φ42

Facemill
φ40~φ66

G-Body

Endmill
φ16~φ40



Low cutting force geometry

Unique 3D geometry insert provides stable cutting and less power consumption.

Multi - flutes specification

High speed and high efficient machining.

Vibration free

Control vibration with combination of MSN carbide shank holder

QM MAX **MQX/QXP Type**

Insert Line-Up

High feed insert



EPMT100312ZER EPMT100312ZER

High feed insert for unfavorable conditions



EPMW100312ZER EPMW100312ZTR EPMW100312ZTR

For high hardened steel



EPHW100316ZTR

Shoulder insert for aluminum



ZPMT1003...ZER-NL
(R0.4, 0.8, 2.0)

Shoulder insert for general steel



ZPMT1003...ZER-PL
(R0.4, 0.8, 2.0)

Shoulder insert for Ti alloy



ZPMT1003...ZER-SL
(R0.4, 0.8, 2.0)

"Mirror Insert" for finishing side & bottom face



YPHW1003...ZER-... **CBN insert**
YPHW100308ZTR-F1

A variety of inserts all fit into the same body.
Multi-purpose cutter that can high feed, square up and finish.

QM MAX **MQX/QXP Type**

■ **Facemill Type**



Through coolant hole



Face Milling



Shoulder Milling



Slotting



Copy Milling



Pocket Milling



Helical Interpolation



● **Highfeed**

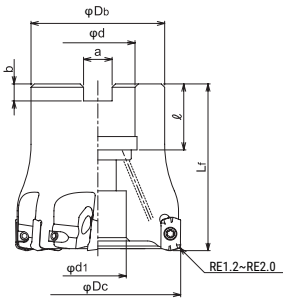

● **Shoulder milling**

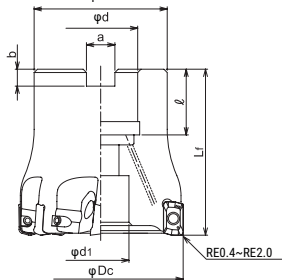

● **High feed (QXP-8066R)**

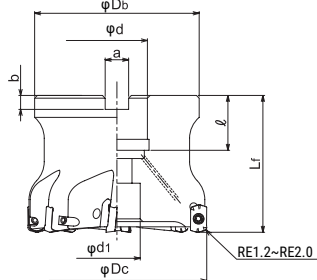

● **Shoulder milling (QXP-8066R)**

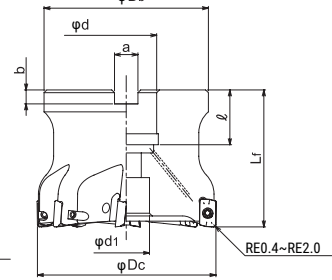

Cat.No	Stock	No. of inserts	Dimensions (mm)								Inserts
			φDc	Lf	φDb	φd	φd1	a	b	ℓ	
QXP-6040R-16	●	6	40	45	35	16	14	8.4	5.6	18	EP**1003**Z*R; ZPMT1003**ZER-**; YPHW1003**Z*R-**
QXP-7040R-16	●	7									
QXP-7050R-22	●	8	50	50	40	22	17	10.4	6.3	20	
QXP-8050R-22	●										
QXP-8052R-22	●										
QXP-8063R-22	●										
QXP-8066R-27	●	66	48	27	20	12.4	7	22			

Screw	Torque(N.m)	Wrench
DSW-2563H	1.1	A-08

QM MAX **MQX/QXP Type**

■ Endmill Shank Type

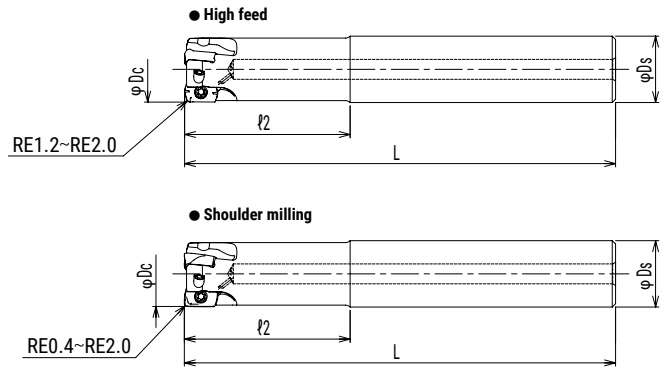
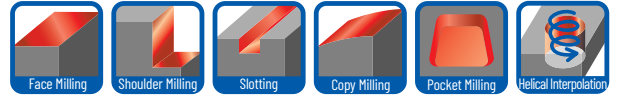

Cat.No	Stock	No. of inserts	Dimensions (mm)					Parts		Inserts
			φDc	ℓ2	L	φD1	φDs	Screws	Wrench	
QXPS2016S16+A	●	2	16	30	100	15	16	TSW-2556H	A-08	EP**1003**Z*R; ZPMT1003**ZER-**; YPHW1003**Z*R-**
QXPS3020S20+A	●	3	20	50	130	18.85	20			
QXPS4025S25+A	●	4	25	60	140	23.6	25	DSW-2563H		

Screw	Torque(N.m)
TSW-2556H	1.1
DSW-2563H	

QM MAX **MQX/QXP Type**

■ **Modular Head Type**



Through coolant hole

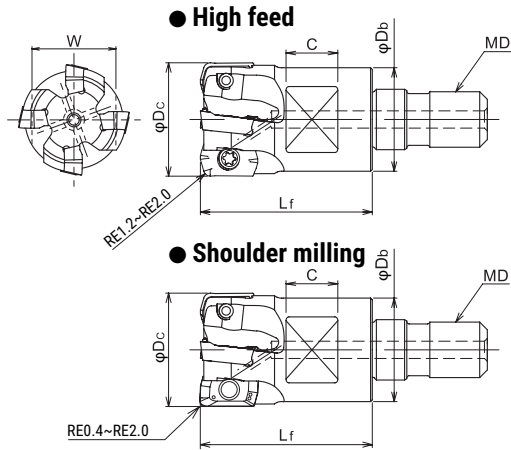
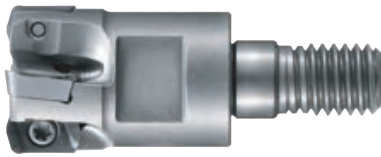

Cat.No	Stock	No. of inserts	Dimensions (mm)						Parts		Inserts
			φDc	Lf	φDb	MD	C	W	Screws	Wrench	
MQX-2016-M8	●	2	16	23	14	M8	8	12	TSW-2556H	A-08	EP**1003**Z*R; ZPMT1003**ZER-**; YPHW1003**Z*R-**
MQX-2017-M8	●		17			M8					
MQX-3020-M10	●	3	20	18	M10	9	14				
MQX-4020-M10	●	4	21		M10						
MQX-4021-M10	●		21	22.5	10	17					
MQX-4025-M12	●	25	M12								
MQX-5025-M12	●	5	M12								
MQX-4026-M12	●	4	26		M12						
MQX-5026-M12	●	4	26		M12						
MQX-5028-M12	●	5	28	23.6	M12	12	22	DSW-2563H			
MQX-5030-M16	●		30	27	M16						
MQX-5032-M16	●	6	32	29	M16						
MQX-6032-M16	●				M16						
MQX-5035-M16	●	5	35	43	M16						
MQX-6035-M16	●				M16						
MQX-6035-M16	●	6	40	32	M16	14	26				
MQX-6040-M16	●				M16						
MQX-7040-M16	●	7	40	32	M16						
MQX-6042-M16	●	6	42	32	M16						

Screw	Torque(N.m)
TSW-2556H	1.1
DSW-2563H	

QM MAX **MQX/QXP Type**

Insert

High feed insert
(EPMT1003 * * ZER)

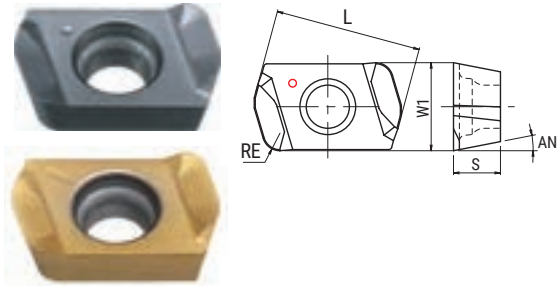

Shoulder insert for general steel
(ZPMT1003 * * ZER-PL)

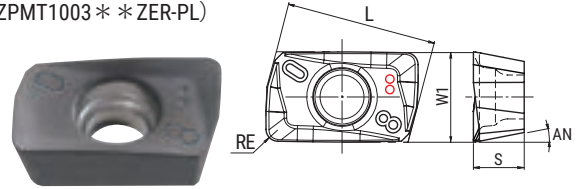

Shoulder insert for Ti alloy
(ZPMT1003 * * ZER-SL)

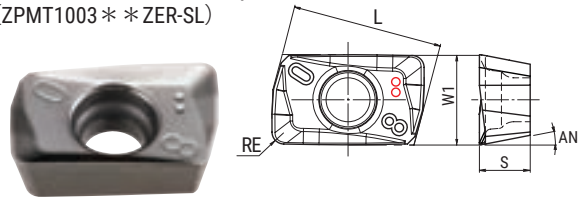

High feed insert for unfavorable conditions
(EPMW100312ZER)

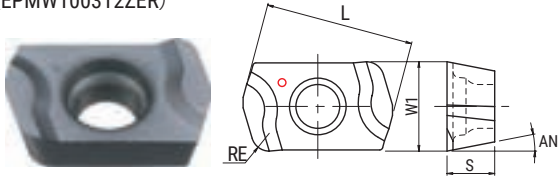

"Mirror Insert" for finishing side & bottom face
(YPHW1003 * * ZER-15) (YPHW100308ZTR-F1) (YPHW100308ZER-F)

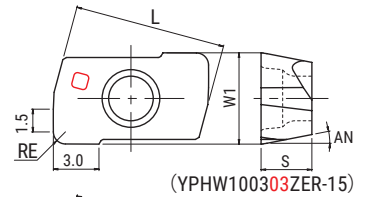

High feed insert for unfavorable conditions
(EPMW100312ZTR)

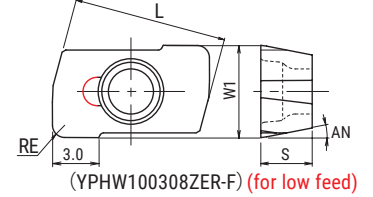
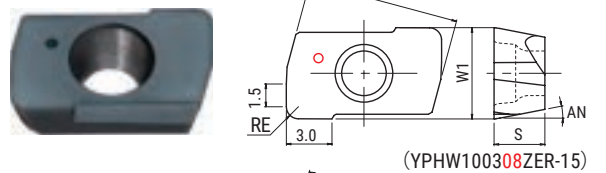
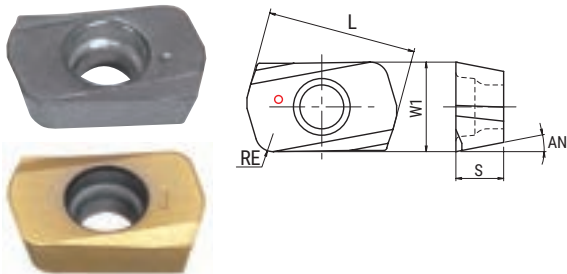

For high hardened steel
(EPHW100316ZTR)

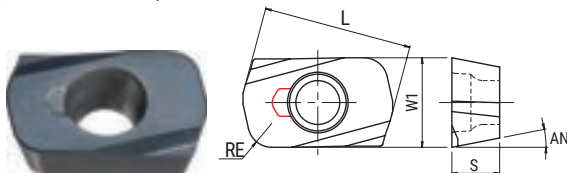

CBN insert

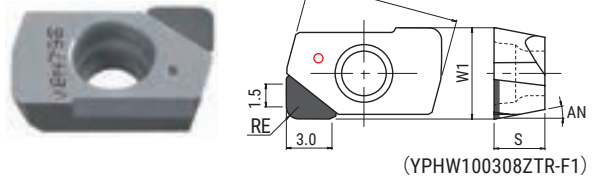

Shoulder insert for aluminum
(ZPMT1003 * * ZER-NL)

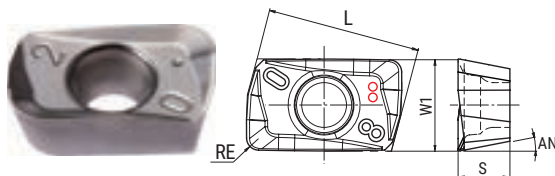

"Mirror Insert" for finishing side & bottom face
(YPHW100320ZER-24)

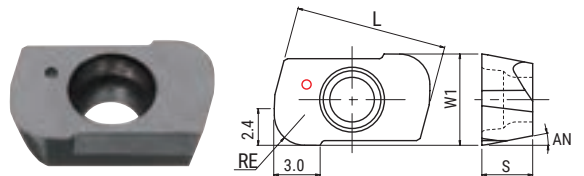

QM MAX **MQX/QXP Type**

■ **Insert**

Type	Cat.No.	Tolerance	PVD coating							Uncoated	Cermet	CBN	Dimensions (mm)					
			JC8118	DH102	JC7518	JC7560	JC8015	JC8050	DS118				DS150	FC18	CX75	JBN795	L	S
High feed insert	EPMT100312ZER	M	●			●		●	●	●				10	3.2	6	1.2	11°
	EPMT100320ZER	M	●											10	3.2	6	2.0	11°
High feed insert for unfavorable conditions	EPMW100312ZER	M	●					●						10	3.2	6	1.2	11°
	EPMW100312ZTR	M	●			●		●						10	3.2	6	1.2	11°
For high hardened steel	EPHW100316ZTR	H	●	●										10	3.2	6	1.6	11°
Shoulder insert for aluminum	ZPMT100304ZER-NL	M								●				10.08	3.4	6	0.4	11°
	ZPMT100308ZER-NL	M								●				10.08	3.4	6	0.8	11°
	ZPMT100320ZER-NL	M								●				10.08	3.4	6	2.0	11°
Shoulder insert for general steel	ZPMT100304ZER-PL	M	●	●				●			●			10.08	3.4	6	0.4	11°
	ZPMT100308ZER-PL	M	●	●				●			●			10.08	3.4	6	0.8	11°
	ZPMT100320ZER-PL	M	●	●				●			●			10.08	3.4	6	2.0	11°
Shoulder insert for Ti alloy	ZPMT100304ZER-SL	M			●				●					10.08	3.4	6	0.4	11°
	ZPMT100308ZER-SL	M			●				●					10.08	3.4	6	0.8	11°
	ZPMT100320ZER-SL	M			●				●					10.08	3.4	6	2.0	11°
"Mirror Insert" for finishing side & bottom face	YPHW100303ZER-15	H	●				●				●			10.06	3.35	6	0.3	11°
	YPHW100308ZER-15	H	●								●			10.06	3.35	6	0.8	11°
	YPHW100308ZER-F	H					●							10.06	3.35	6	0.8	11°
	YPHW100308ZTR-F1	H										●		10.06	3.35	6	0.8	11°
	YPHW100320ZER-24	H	●				●							10.06	3.35	6	2.0	11°

GRADE MARKING



JC8118 / DS118

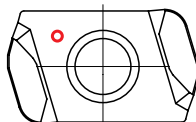

JC8050 / JC7560 / DS150

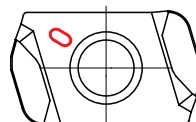

QM MAX **MQX/QXP Type**

Insert selection guide

Material	Carbon steel (S50C, S55C) below 250HB						Tool & die steel (SKD61, SKD11) below 255HB						Mold steel (HPM7, PX5, P20) 30-36HRC						Mold steel (NAK80, HPM1, P21) 38-43HRC					
	Cat.No.	Grade					Cat.No.	Grade					Cat.No.	Grade					Cat.No.	Grade				
EPMT1003**ZER	☆	☆	☆				☆	☆	☆				☆	☆	☆				☆	☆				
EPMW100312ZER																			○					
EPMW100312ZTR	○	○	◎				○	○	◎				○	○	◎				◎	○				
EPHW100316ZTR																								

Material	Hardened die steel (SKD61, DAC, DHA) 42-52 HRC						Hardened die steel (SKD11, SLD, DC11) 55-62HRC						Grey cast iron (FC, FCD) below 300HB						Stainless steel (SUS304) below 250HB					
	Cat.No.	Grade					Cat.No.	Grade					Cat.No.	Grade					Cat.No.	Grade				
EPMT1003**ZER	☆						×	×					○						◎	○				
EPMW100312ZER	○						○						◎						●					
EPMW100312ZTR	●						●						●	○										
EPHW100316ZTR	◎									◎														

Material	Titanium alloy (Ti-6Al-4V)						Heat resistant alloy (INCO718)					
	Cat.No.	Grade					Cat.No.	Grade				
EPMT1003**ZER	○	○	●		○	◎	◎	○	○		○	○
EPMW100312ZER		●						●				
EPMW100312ZTR												
EPHW100316ZTR												

- EPMT Type : with chip breaker
 - EPMW Type : without chip breaker
 - EPMW Type : without chip breaker
- ◎ : First choice
 ○ : For general milling
 ● : For unstable milling
 ☆ : For light cutting force
 × : Not recommended

Definition of corner shape for programming

• EPMT/W Type (RE=R1.2)

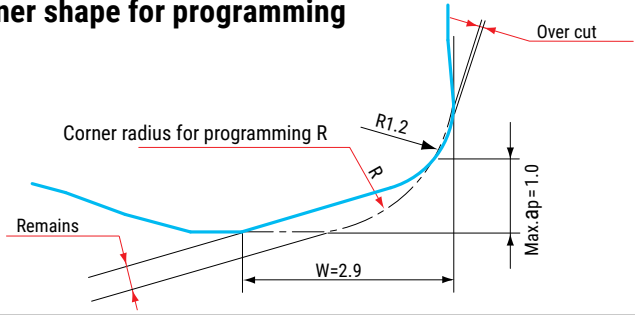

Corner radius for programming R	Over cut	Remains
R1.0	0	0.57
R1.5 (Std.)	0	0.45
R2.0	0.04	0.33
R2.5	0.21	0.21
R3.0	0.40	0.09

• EPMT Type (RE=R2.0)

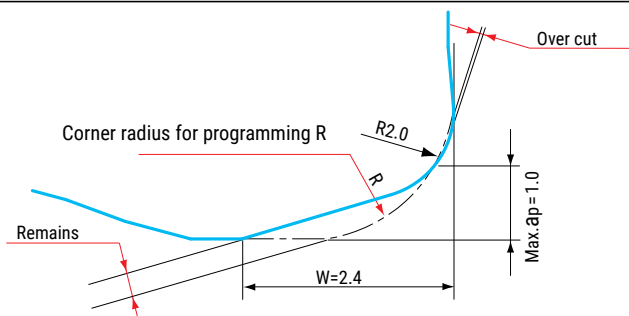

Corner radius for programming R	Over cut	Remains
R1.0	0	0.51
R1.5	0	0.31
R2.0 (Std.)	0	0.13
R2.5	0.12	0.04
R3.0	0.32	0

• EPHW Type

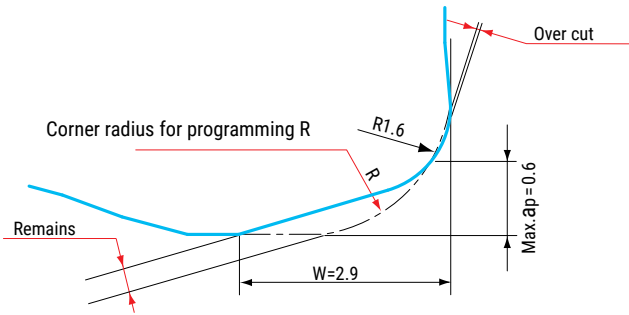

Corner radius for programming R	Over cut	Remains
R1.0	0	0.42
R1.5 (Std.)	0	0.33
R2.0	0.01	0.23
R2.5	0.17	0.14
R3.0	0.37	0.05

QM MAX **MQX/QXP Type**

■ **Recommended Data for Profile Milling**

Ramping

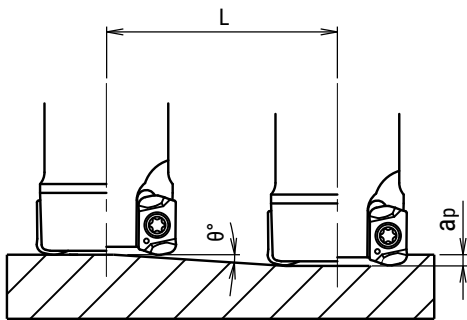

Helical interpolation

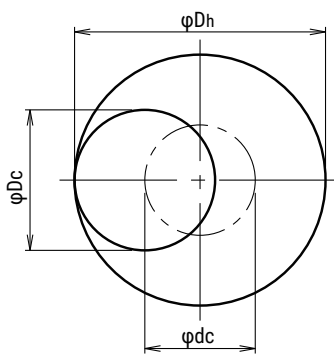

- Calculation of tool pass dia.

$$\varphi_{dc} = \varphi_{Dh} - \varphi_{Dc}$$

Tool pass dia. Bore dia. Tool Dia.

- Depth of cut per one circuit should not exceed max. depth of cut Ap
- Down cutting is recommended, tool pass rotation should be counterclockwise

- In case of ramping and helical interpolation, apply 70% or less feed (Vf) from standard cutting condition table
- In case of drilling, apply 50% or less Z axis feed (F) from standard cutting condition table
- Long consecutive chips may result in case of drilling, confirm safe operating conditions

■ **EPM*100312ZER**

Cat.No.	Tool dia.	Effective Cutting dia.	Max.depth of cut : ap	Ramping		Helical interpolation		Max.drilling depth Z(mm)
				Max.ramping angle θ	Max.depth of cut (ap) Total cutting length L (mm)	Min.Bore dia.	Max.Bore dia.	
QXP-*040R-16	40	34.1	1	0.5	114.6	70	78	0.6
QXP-*050R-*	50	44.1	1	0.4	143.2	90	98	0.6
QXP-8052R-22	52	46.1	1	0.35	163.7	94	102	0.6
QXP-8063R-*	63	57.1	1	0.3	191	116	124	0.6
QXP-8066R-*	66	60.1	1	0.3	191	122	130	0.6
QXP-2016-30-S16	16	10.2	0.8	1.8	25.5	22	30	0.6
QXP-3020-50-S20	20	14.1	0.8	1.4	32.7	30	38	0.6
QXP-4025-60-S25	25	19.1	0.8	1	45.8	40	48	0.6
QXP-5032-70-S32	32	26.1	0.8	0.7	65.5	54	62	0.5
QXP-6040-45-S32	40	34.1	0.8	0.5	91.7	70	78	0.6
MQX-*016-M8	16	10.2	0.8	1.8	25.5	22	30	0.6
MQX-*017-M8	17	11.2	0.8	1.6	28.6	24	32	0.6
MQX-*020-M10	20	14.1	0.8	1.4	32.7	30	38	0.6
MQX-*021-M10	21	15.1	0.8	1.3	35.3	32	40	0.6
MQX-*025-M12	25	19.1	0.8	1	45.8	40	48	0.6
MQX-*026-M12	26	20.1	0.8	0.95	48.2	42	50	0.6
MQX-*028-M12	28	22.1	0.8	0.85	53.9	46	54	0.6
MQX-*030-M16	30	24.1	0.8	0.8	57.3	50	58	0.5
MQX-*032-M16	32	26.1	0.8	0.7	65.5	54	62	0.5
MQX-*035-M16	35	29.1	0.8	0.6	76.4	60	68	0.5
MQX-*040-M16	40	34.1	0.8	0.5	91.7	70	78	0.6
MQX-*042-M16	42	36.2	0.8	0.45	101.9	74	82	0.6

QM MAX

MQX/QXP Type

■ Recommended Data for Profile Milling

■ **EPMT100320ZER**

Cat.No.	Tool dia.	Effective Cutting dia.	Max.depth of cut : ap	Ramping		Helical interpolation		Max.drilling depth Z(mm)
				Max.ramping angle θ	Max.depth of cut (ap) Total cutting length L (mm)	Min.Bore dia.	Max.Bore dia.	
QXP- *040R-16	40	35.1	1	0.55	104.2	72	78	0.7
QXP- *050R- * *	50	45.1	1	0.4	143.2	92	98	0.7
QXP-8052R-22	52	47.2	1	0.4	143.2	96	102	0.7
QXP-8063R- * *	63	58.2	1	0.3	191	118	124	0.7
QXP-8066R- * *	66	61.2	1	0.3	191	124	130	0.7
QXP-2016-30-S16	16	11.2	0.8	2.3	19.9	24	30	0.7
QXP-3020-50-S20	20	15.1	0.8	1.5	30.6	32	38	0.7
QXP-4025-60-S25	25	20.1	0.8	1.1	41.7	42	48	0.6
QXP-5032-70-S32	32	27.1	0.8	0.75	61.1	56	62	0.6
QXP-6040-45-S32	40	35.1	0.8	0.55	83.3	72	78	0.7
MQX- *016-M8	16	11.2	0.8	2.3	19.9	24	30	0.7
MQX- *017-M8	17	12.2	0.8	2	22.9	26	32	0.7
MQX- *020-M10	20	15.1	0.8	1.5	30.6	32	38	0.7
MQX- *021-M10	21	16.1	0.8	1.4	32.7	34	40	0.7
MQX- *025-M12	25	20.1	0.8	1.1	41.7	42	48	0.6
MQX- *026-M12	26	21.1	0.8	1	45.8	44	50	0.6
MQX- *028-M12	28	23.1	0.8	0.9	50.9	48	54	0.6
MQX- *030-M16	30	25.1	0.8	0.85	53.9	52	58	0.6
MQX- *032-M16	32	27.1	0.8	0.75	61.1	56	62	0.6
MQX- *035-M16	35	30.1	0.8	0.65	70.5	62	68	0.6
MQX- *040-M16	40	35.1	0.8	0.55	83.3	72	78	0.7
MQX- *042-M16	42	37.1	0.8	0.55	83.3	76	82	0.7

■ **EPMW100312ZTR**

Cat.No.	Tool dia.	Effective Cutting dia.	Max.depth of cut : ap	Ramping		Helical interpolation		Max.drilling depth Z(mm)
				Max.ramping angle θ	Max.depth of cut (ap) Total cutting length L (mm)	Min.Bore dia.	Max.Bore dia.	
QXP- *040R-16	40	34.1	1	0.4	143.2	70	78	0.6
QXP- *050R- * *	50	44.1	1	0.3	191	90	98	0.6
QXP-8052R-22	52	46.1	1	0.25	229.2	94	102	0.6
QXP-8063R- * *	63	57.1	1	0.2	286.5	116	124	0.6
QXP-8066R- * *	66	60.1	1	0.2	286.5	122	130	0.6
QXP-2016-30-S16	16	10.2	0.8	1.7	27	22	30	0.6
QXP-3020-50-S20	20	14.1	0.8	1.3	35.3	30	38	0.6
QXP-4025-60-S25	25	19.1	0.8	0.9	50.9	40	48	0.6
QXP-5032-70-S32	32	26.1	0.8	0.6	76.4	54	62	0.5
QXP-6040-45-S32	40	34.1	0.8	0.4	114.6	70	78	0.6
MQX- *016-M8	16	10.2	0.8	1.7	27	22	30	0.6
MQX- *017-M8	17	11.2	0.8	1.5	30.6	24	32	0.6
MQX- *020-M10	20	14.1	0.8	1.3	35.3	30	38	0.6
MQX- *021-M10	21	15.1	0.8	1.2	38.2	32	40	0.6
MQX- *025-M12	25	19.1	0.8	0.9	50.9	40	48	0.6
MQX- *026-M12	26	20.1	0.8	0.85	53.9	42	50	0.6
MQX- *028-M12	28	22.1	0.8	0.75	61.1	46	54	0.6
MQX- *030-M16	30	24.1	0.8	0.7	65.5	50	58	0.5
MQX- *032-M16	32	26.1	0.8	0.6	76.4	54	62	0.5
MQX- *035-M16	35	29.1	0.8	0.5	91.7	60	68	0.5
MQX- *040-M16	40	34.1	0.8	0.4	114.6	70	78	0.6
MQX- *042-M16	42	36.2	0.8	0.35	131	74	82	0.6

QM MAX**MQX/QXP Type****EPHW100316ZTR**

Cat.No.	Tool dia.	Effective Cutting dia.	Max.depth of cut : ap	Ramping		Helical interpolation		Max.drilling depth Z(mm)
				Max.ramping angle θ	Max.depth of cut (ap) Total cutting length L (mm)	Min.Bore dia.	Max.Bore dia.	
QXP-*040R-16	40	34.1	0.6	0.3	114.6	70	78	0.6
QXP-*050R-**	50	44.1	0.6	0.2	171.9	90	98	0.6
QXP-8052R-22	52	46.1	0.6	0.2	171.9	94	102	0.6
QXP-8063R-**	63	57.1	0.6	0.15	229.2	116	124	0.6
QXP-8066R-**	66	60.1	0.6	0.15	229.2	122	130	0.6
QXP-2016-30-S16	16	10.2	0.6	1.1	31.2	22	30	0.6
QXP-3020-50-S20	20	14.1	0.6	0.8	43	30	38	0.6
QXP-4025-60-S25	25	19.1	0.6	0.55	62.5	40	48	0.6
QXP-5032-70-S32	32	26.1	0.6	0.4	85.9	54	62	0.5
QXP-6040-45-S32	40	34.1	0.6	0.3	114.6	70	78	0.6
MQX-*016-M8	16	10.2	0.6	1.1	31.2	22	30	0.6
MQX-*017-M8	17	11.2	0.6	1	34.4	24	32	0.6
MQX-*020-M10	20	14.1	0.6	0.8	43	30	38	0.6
MQX-*021-M10	21	15.1	0.6	0.7	49.1	32	40	0.6
MQX-*025-M12	25	19.1	0.6	0.55	62.5	40	48	0.6
MQX-*026-M12	26	20.1	0.6	0.5	68.8	42	50	0.6
MQX-*028-M12	28	22.1	0.6	0.45	76.4	46	54	0.6
MQX-*030-M16	30	24.1	0.6	0.4	85.9	50	58	0.5
MQX-*032-M16	32	26.1	0.6	0.4	85.9	54	62	0.5
MQX-*035-M16	35	29.1	0.6	0.35	98.2	60	68	0.5
MQX-*040-M16	40	34.1	0.6	0.3	114.6	70	78	0.6
MQX-*042-M16	42	36.2	0.6	0.25	137.5	74	82	0.6

ZPMT100304ZER-**

Cat.No.	Tool dia.	Effective Cutting dia.	Max.depth of cut : ap	Ramping		Helical interpolation		Max.drilling depth Z(mm)
				Max.ramping angle θ	Max.depth of cut (ap) Total cutting length L (mm)	Min.Bore dia.	Max.Bore dia.	
QXP-*040R-16	40	39	1	0.95	60.3	75.6	78.4	0.6
QXP-*050R-**	50	49	1	0.7	81.8	95.6	98.4	0.6
QXP-8052R-22	52	51	1	0.65	88.1	99.6	102.4	0.6
QXP-8063R-**	63	62	1	0.55	104.2	121.6	124.4	0.6
QXP-8066R-**	66	65	1	0.5	114.6	127.6	130.4	0.6
QXP-2016-30-S16	16	15	0.8	3	15.3	27.6	30.4	0.6
QXP-3020-50-S20	20	19	0.8	2.4	19.1	35.6	38.4	0.6
QXP-4025-60-S25	25	24	0.8	1.7	27	45.6	48.4	0.6
QXP-5032-70-S32	32	31	0.8	1.2	38.2	59.6	62.4	0.5
QXP-6040-45-S32	40	39	0.8	0.95	48.2	75.6	78.4	0.6
MQX-*016-M8	16	15	0.8	3	15.3	27.6	30.4	0.6
MQX-*017-M8	17	16	0.8	3.2	14.3	29.6	32.4	0.6
MQX-*020-M10	20	19	0.8	2.4	19.1	35.6	38.4	0.6
MQX-*021-M10	21	20	0.8	2.2	20.8	37.6	40.4	0.6
MQX-*025-M12	25	24	0.8	1.7	27	45.6	48.4	0.6
MQX-*026-M12	26	25	0.8	1.6	28.6	47.6	50.4	0.6
MQX-*028-M12	28	27	0.8	1.5	30.6	51.6	54.4	0.6
MQX-*030-M16	30	29	0.8	1.3	35.3	55.6	58.4	0.5
MQX-*032-M16	32	31	0.8	1.2	38.2	59.6	62.4	0.5
MQX-*035-M16	35	34	0.8	1.1	41.7	65.6	68.4	0.5
MQX-*040-M16	40	39	0.8	0.95	48.2	75.6	78.4	0.6
MQX-*042-M16	42	41	0.8	0.85	53.9	79.6	82.4	0.6

QM MAX

MQX/QXP Type

■ **Recommended Data for Profile Milling**

■ **ZPMT100308ZER-****

Cat.No.	Tool dia.	Effective Cutting dia.	Max.depth of cut : ap	Ramping		Helical interpolation		Max.drilling depth Z(mm)
				Max.ramping angle θ	Max.depth of cut (ap) Total cutting length L (mm)	Min.Bore dia.	Max.Bore dia.	
QXP- * 040R-16	40	38.2	1	0.95	60.3	74.8	77.6	0.6
QXP- * 050R- * *	50	48.2	1	0.7	81.8	94.8	97.6	0.6
QXP-8052R-22	52	50.2	1	0.65	88.1	98.8	101.6	0.6
QXP-8063R- * *	63	61.2	1	0.55	104.2	120.8	123.6	0.6
QXP-8066R- * *	66	64.2	1	0.5	114.6	126.8	129.6	0.6
QXP-2016-30-S16	16	14.2	0.8	3	15.3	26.8	29.6	0.6
QXP-3020-50-S20	20	18.2	0.8	2.4	19.1	34.8	37.6	0.6
QXP-4025-60-S25	25	23.2	0.8	1.7	27	44.8	47.6	0.6
QXP-5032-70-S32	32	30.2	0.8	1.2	38.2	58.8	61.6	0.5
QXP-6040-45-S32	40	38.2	0.8	0.95	48.2	74.8	77.6	0.6
MQX- * 016-M8	16	14.2	0.8	3	15.3	26.8	29.6	0.6
MQX- * 017-M8	17	15.2	0.8	3.2	14.3	28.8	31.6	0.6
MQX- * 020-M10	20	18.2	0.8	2.4	19.1	34.8	37.6	0.6
MQX- * 021-M10	21	19.2	0.8	2.2	20.8	36.8	39.6	0.6
MQX- * 025-M12	25	23.2	0.8	1.7	27	44.8	47.6	0.6
MQX- * 026-M12	26	24.2	0.8	1.6	28.6	46.8	49.6	0.6
MQX- * 028-M12	28	26.2	0.8	1.5	30.6	50.8	53.6	0.6
MQX- * 030-M16	30	28.2	0.8	1.3	35.3	54.8	57.6	0.5
MQX- * 032-M16	32	30.2	0.8	1.2	38.2	58.8	61.6	0.5
MQX- * 035-M16	35	33.2	0.8	1.1	41.7	64.8	67.6	0.5
MQX- * 040-M16	40	38.2	0.8	0.95	48.2	74.8	77.6	0.6
MQX- * 042-M16	42	40.2	0.8	0.85	53.9	78.8	81.6	0.6

■ **ZPMT100320ZER-****

Cat.No.	Tool dia.	Effective Cutting dia.	Max.depth of cut : ap	Ramping		Helical interpolation		Max.drilling depth Z(mm)
				Max.ramping angle θ	Max.depth of cut (ap) Total cutting length L (mm)	Min.Bore dia.	Max.Bore dia.	
QXP- * 040R-16	40	35.8	1	0.95	60.3	70	75.2	0.6
QXP- * 050R- * *	50	45.8	1	0.7	81.8	90	95.2	0.6
QXP-8052R-22	52	47.8	1	0.65	88.1	94	99.2	0.6
QXP-8063R- * *	63	58.8	1	0.55	104.2	116	121.2	0.6
QXP-8066R- * *	66	61.8	1	0.5	114.6	122	127.2	0.6
QXP-2016-30-S16	16	11.8	0.8	3	15.3	22	27.2	0.6
QXP-3020-50-S20	20	15.8	0.8	2.4	19.1	30	35.2	0.6
QXP-4025-60-S25	25	20.8	0.8	1.7	27	40	45.2	0.6
QXP-5032-70-S32	32	27.8	0.8	1.2	38.2	54	59.2	0.5
QXP-6040-45-S32	40	35.8	0.8	0.95	48.2	70	75.2	0.6
MQX- * 016-M8	16	11.8	0.8	3	15.3	22	27.2	0.6
MQX- * 017-M8	17	12.8	0.8	3.2	14.3	24	29.2	0.6
MQX- * 020-M10	20	15.8	0.8	2.4	19.1	30	35.2	0.6
MQX- * 021-M10	21	16.8	0.8	2.2	20.8	32	37.2	0.6
MQX- * 025-M12	25	20.8	0.8	1.7	27	40	45.2	0.6
MQX- * 026-M12	26	21.8	0.8	1.6	28.6	42	47.2	0.6
MQX- * 028-M12	28	23.8	0.8	1.5	30.6	46	51.2	0.6
MQX- * 030-M16	30	25.8	0.8	1.3	35.3	50	55.2	0.5
MQX- * 032-M16	32	27.8	0.8	1.2	38.2	54	59.2	0.5
MQX- * 035-M16	35	30.8	0.8	1.1	41.7	60	65.2	0.5
MQX- * 040-M16	40	35.8	0.8	0.95	48.2	70	75.2	0.6
MQX- * 042-M16	42	37.8	0.8	0.85	53.9	74	79.2	0.6

QM MAX**MQX/QXP Type****YPHW100303ZER-15**

Cat.No.	Tool dia.	Effective Cutting dia.	Max.depth of cut : ap	Ramping		Helical interpolation		Max.drilling depth Z(mm)
				Max.ramping angle θ	Max.depth of cut (ap) Total cutting length L (mm)	Min.Bore dia.	Max.Bore dia.	
QXP- *040R-16	40	39.3	0.3	1	17.2	77	78.7	0.3
QXP- *050R- * *	50	49.3	0.3	0.75	22.9	97	98.7	0.3
QXP-8052R-22	52	51.3	0.3	0.7	24.6	101	102.7	0.3
QXP-8063R- * *	63	62.3	0.3	0.6	28.6	123	124.7	0.3
QXP-8066R- * *	66	65.3	0.3	0.55	31.3	129	130.7	0.3
QXP-2016-30-S16	16	15.3	0.3	1.3	13.2	29	30.7	0.2
QXP-3020-50-S20	20	19.3	0.3	2.1	8.2	37	38.7	0.3
QXP-4025-60-S25	25	24.3	0.3	1.8	9.5	47	48.7	0.3
QXP-5032-70-S32	32	31.3	0.3	1.3	13.2	61	62.7	0.3
QXP-6040-45-S32	40	39.3	0.3	1	17.2	77	78.7	0.3
MQX- *016-M8	16	15.3	0.3	1.3	13.2	29	30.7	0.2
MQX- *017-M8	17	16.3	0.3	1.7	10.1	31	32.7	0.3
MQX- *020-M10	20	19.3	0.3	2.1	8.2	37	38.7	0.3
MQX- *021-M10	21	20.3	0.3	2.4	7.2	39	40.7	0.3
MQX- *025-M12	25	24.3	0.3	1.8	9.5	47	48.7	0.3
MQX- *026-M12	26	25.3	0.3	1.7	10.1	49	50.7	0.3
MQX- *028-M12	28	27.3	0.3	1.6	10.7	53	54.7	0.3
MQX- *030-M16	30	29.3	0.3	1.4	12.3	57	58.7	0.3
MQX- *032-M16	32	31.3	0.3	1.3	13.2	61	62.7	0.3
MQX- *035-M16	35	34.3	0.3	1.2	14.3	67	68.7	0.3
MQX- *040-M16	40	39.3	0.3	1	17.2	77	78.7	0.3
MQX- *042-M16	42	41.3	0.3	0.9	19.1	81	82.7	0.3

YPHW100308ZER-15

Cat.No.	Tool dia.	Effective Cutting dia.	Max.depth of cut : ap	Ramping		Helical interpolation		Max.drilling depth Z(mm)
				Max.ramping angle θ	Max.depth of cut (ap) Total cutting length L (mm)	Min.Bore dia.	Max.Bore dia.	
QXP- *040R-16	40	38.3	0.3	1	17.2	75	77.7	0.3
QXP- *050R- * *	50	48.3	0.3	0.75	22.9	95	97.7	0.3
QXP-8052R-22	52	50.3	0.3	0.7	24.6	99	101.7	0.3
QXP-8063R- * *	63	61.3	0.3	0.6	28.6	121	123.7	0.3
QXP-8066R- * *	66	64.3	0.3	0.55	31.3	127	129.7	0.3
QXP-2016-30-S16	16	14.3	0.3	1.4	12.3	27	29.7	0.2
QXP-3020-50-S20	20	18.3	0.3	2.2	7.8	35	37.7	0.3
QXP-4025-60-S25	25	23.3	0.3	1.9	9	45	47.7	0.3
QXP-5032-70-S32	32	30.3	0.3	1.4	12.3	59	61.7	0.3
QXP-6040-45-S32	40	38.3	0.3	1	17.2	75	77.7	0.3
MQX- *016-M8	16	14.3	0.3	1.4	12.3	27	29.7	0.2
MQX- *017-M8	17	15.3	0.3	1.8	9.5	29	31.7	0.3
MQX- *020-M10	20	18.3	0.3	2.2	7.8	35	37.7	0.3
MQX- *021-M10	21	19.3	0.3	2.5	6.9	37	39.7	0.3
MQX- *025-M12	25	23.3	0.3	1.9	9	45	47.7	0.3
MQX- *026-M12	26	24.3	0.3	1.8	9.5	47	49.7	0.3
MQX- *028-M12	28	26.3	0.3	1.7	10.1	51	53.7	0.3
MQX- *030-M16	30	28.3	0.3	1.5	11.5	55	57.7	0.3
MQX- *032-M16	32	30.3	0.3	1.4	12.3	59	61.7	0.3
MQX- *035-M16	35	33.3	0.3	1.2	14.3	65	67.7	0.3
MQX- *040-M16	40	38.3	0.3	1	17.2	75	77.7	0.3
MQX- *042-M16	42	40.3	0.3	0.9	19.1	79	81.7	0.3

QM MAX**MQX/QXP Type**■ **Recommended Data for Profile Milling**■ **YPHW100320ZER-24**

Cat.No.	Tool dia.	Effective Cutting dia.	Max.depth of cut : ap	Ramping		Helical interpolation		Max.drilling depth Z(mm)
				Max.ramping angle θ	Max.depth of cut (ap) Total cutting length L (mm)	Min.Bore dia.	Max.Bore dia.	
QXP- *040R-16	40	35.9	0.3	1.1	15.6	70.2	75.3	0.3
QXP- *050R- * *	50	45.9	0.3	0.9	19.1	90.2	95.3	0.3
QXP-8052R-22	52	47.9	0.3	0.85	20.2	94.2	99.3	0.3
QXP-8063R- * *	63	58.9	0.3	0.65	26.4	116.2	121.3	0.3
QXP-8066R- * *	66	61.9	0.3	0.65	26.4	122.2	127.3	0.3
QXP-2016-30-S16	16	11.9	0.3	1.9	9	22.2	27.3	0.3
QXP-3020-50-S20	20	15.9	0.3	2.5	6.9	30.2	35.3	0.3
QXP-4025-60-S25	25	20.9	0.3	2.2	7.8	40.2	45.3	0.3
QXP-5032-70-S32	32	27.9	0.3	1.5	11.5	54.2	59.3	0.3
QXP-6040-45-S32	40	35.9	0.3	1.1	15.6	70.2	75.3	0.3
MQX- *016-M8	16	11.9	0.3	1.9	9	22.2	27.3	0.3
MQX- *017-M8	17	12.9	0.3	2.2	7.8	24.2	29.3	0.3
MQX- *020-M10	20	15.9	0.3	2.5	6.9	30.2	35.3	0.3
MQX- *021-M10	21	16.9	0.3	2.8	6.1	32.2	37.3	0.3
MQX- *025-M12	25	20.9	0.3	2.2	7.8	40.2	45.3	0.3
MQX- *026-M12	26	21.9	0.3	2	8.6	42.2	47.3	0.3
MQX- *028-M12	28	23.9	0.3	1.8	9.5	46.2	51.3	0.3
MQX- *030-M16	30	25.9	0.3	1.6	10.7	50.2	55.3	0.3
MQX- *032-M16	32	27.9	0.3	1.5	11.5	54.2	59.3	0.3
MQX- *035-M16	35	30.9	0.3	1.4	12.3	60.2	65.3	0.3
MQX- *040-M16	40	35.9	0.3	1.1	15.6	70.2	75.3	0.3
MQX- *042-M16	42	37.9	0.3	1.1	15.6	74.2	79.3	0.3

QM MAX**MQX/QXP Type**

■ Recommended cutting conditions

● MQX Type (EPMT/W insert) + MSN shank

①

Material	Grade	Tool dia.(mm)														
		16/17					20					20/21				
		2N					3N					4N				
		ℓ (mm)	ap (mm)	ae (mm)	n (min ⁻¹)	Vf (mm/min)	ℓ (mm)	ap (mm)	ae (mm)	n (min ⁻¹)	Vf (mm/min)	ℓ (mm)	ap (mm)	ae (mm)	n (min ⁻¹)	Vf (mm/min)
Carbon steel (S50C, S55C) below 250HB	JC7560 (JC8050)	~70	0.6	~10	3,600	4,900	~70	0.6	~14	2,850	5,800	~70	0.6	~14	2,850	7,700
	(JC8118)	120	0.5	~10	3,600	4,500	120	0.5	~14	2,850	5,300	120	0.5	~14	2,850	7,000
		160	0.35	~10	3,000	4,200	190	0.35	~14	2,400	4,900	190	0.35	~14	2,400	6,500
Tool & die steel (SKD61, SKD11) below 255HB	JC7560 (JC8050)	~70	0.6	~10	3,600	4,900	~70	0.6	~14	2,850	5,800	~70	0.6	~14	2,850	7,700
	(JC8118)	120	0.5	~10	3,600	4,500	120	0.5	~14	2,850	5,300	120	0.5	~14	2,850	7,000
		160	0.35	~10	3,000	4,200	190	0.35	~14	2,400	4,900	190	0.35	~14	2,400	6,500
Mold steel (HPM7, PX5, P20) 30-36 HRC	JC8118 (JC7560)	~70	0.6	~10	3,600	4,900	~70	0.6	~14	2,850	5,800	~70	0.6	~14	2,850	7,700
	(JC8050)	120	0.5	~10	3,600	4,500	120	0.5	~14	2,850	5,300	120	0.5	~14	2,850	7,000
		160	0.35	~10	3,000	4,200	190	0.35	~14	2,400	4,900	190	0.35	~14	2,400	6,500
Mold steel (NAK80, HPM1, P21) 38-43HRC	JC8118 (JC8050)	~70	0.5	~10	1,900	2,600	~70	0.5	~14	1,500	3,050	~70	0.5	~14	1,500	4,050
		120	0.3	~10	1,900	2,400	120	0.3	~14	1,500	2,800	120	0.3	~14	1,500	3,700
		160	0.2	~10	1,600	2,200	190	0.2	~14	1,250	2,600	190	0.2	~14	1,250	3,400
Hardened die steel (SKD61, DAC, DHA) 42-52HRC	JC8118 (JC8050)	~70	0.4	~10	1,400	1,400	~70	0.4	~14	1,100	1,650	~70	0.4	~14	1,100	2,200
		120	0.3	~10	1,400	1,400	120	0.3	~14	1,100	1,650	120	0.3	~14	1,100	2,200
		160	—	—	—	—	190	—	—	—	—	190	—	—	—	—
Hardened die steel (SKD11, SL, DC11) 55-62HRC	JC8118 EPMWType	~70	0.15	~10	600	180	~70	0.15	~14	500	230	~70	0.15	~14	500	300
		120	0.1	~10	600	180	120	0.1	~14	500	230	120	0.1	~14	500	300
		160	—	—	—	—	190	—	—	—	—	190	—	—	—	—
Grey & Nodular cast iron (FC, FCD) below 300HB	JC8118 (JC7560)	~70	0.8	~10	3,000	5,000	~70	0.8	~14	2,400	6,000	~70	0.8	~14	2,400	8,000
		120	0.6	~10	3,000	4,500	120	0.6	~14	2,400	5,400	120	0.6	~14	2,400	7,200
		160	0.5	~10	2,200	3,750	190	0.5	~14	1,750	4,500	190	0.5	~14	1,750	6,000
Stainless steel (SUS304) below 250HB	JC8050 (JC7560)	~70	0.6	~10	3,100	4,200	~70	0.6	~14	2,500	5,100	~70	0.6	~14	2,500	6,800
		120	0.5	~10	3,000	4,000	120	0.5	~14	2,400	4,900	120	0.5	~14	2,400	6,500
		160	0.35	~10	3,000	4,000	190	0.35	~14	2,400	4,900	190	0.35	~14	2,400	6,500
Titanium alloy (Ti-6Al-4V)	DS150 (DS118)	~70	0.5	~10	1,200	960	~70	0.5	~14	950	1,140	~70	0.5	~14	950	1,500
	(JC8050)	120	0.3	~10	1,200	960	120	0.3	~14	950	1,140	120	0.3	~14	950	1,500
		160	0.2	~10	1,200	960	190	0.2	~14	950	1,140	190	0.2	~14	950	1,500
Heat resistant alloy (INCO718)	JC8118 (DS118)	~70	0.5	~10	630	380	~70	0.5	~14	500	450	~70	0.5	~14	500	600
	(DS150)	120	0.3	~10	630	380	120	0.3	~14	500	450	120	0.3	~14	500	600
		160	0.2	~10	630	380	190	0.2	~14	500	450	190	0.2	~14	500	600

Note

1. Please adjust cutting conditions according to machine rigidity or work rigidity.
2. In case of chatter occurring, recommended to reduce ap or rpm and keep feed per tooth.
3. ap should be reduced when using on low rigidity machine.
4. Use air blow.
5. When using ZPMT100320ZER-PL insert for High feed milling, reduce cutting conditions above by 10-30%.
6. When using Endmill type, reduce cutting conditions above by 10-20%.

QM MAX **MQX/QXP Type**

- Recommended cutting conditions
- MQX Type (EPMT/W insert) + MSN shank

1

Material	Grade	Tool dia.(mm)									
		25/26					25/26/28				
		4N					5N				
		ℓ (mm)	ap (mm)	ae (mm)	n (min ⁻¹)	Vf (mm/min)	ℓ (mm)	ap (mm)	ae (mm)	n (min ⁻¹)	Vf (mm/min)
Carbon steel (S50C, S55C) below 250HB	JC7560 (JC8050) (JC8118)	~90	0.8	~19	2,300	6,200	~90	0.8	~19	2,300	7,700
		140	0.6	~19	2,300	5,600	140	0.6	~19	2,300	7,000
		210	0.4	~19	1,900	5,200	210	0.4	~19	1,900	6,500
Tool & die steel (SKD61, SKD11) below 255HB	JC7560 (JC8050) (JC8118)	~90	0.8	~19	2,300	6,200	~90	0.8	~19	2,300	7,700
		140	0.6	~19	2,300	5,600	140	0.6	~19	2,300	7,000
		210	0.4	~19	1,900	5,200	210	0.4	~19	1,900	6,500
Mold steel (HPM7, PX5, P20) 30-36 HRC	JC8118 (JC7560) (JC8050)	~90	0.8	~19	2,300	6,200	~90	0.8	~19	2,300	7,700
		140	0.6	~19	2,300	5,600	140	0.6	~19	2,300	7,000
		210	0.4	~19	1,900	5,200	210	0.4	~19	1,900	6,500
Mold steel (NAK80, HPM1, P21) 38-43HRC	JC8118 (JC8050)	~90	0.6	~19	1,200	3,250	~90	0.6	~19	1,200	4,050
		140	0.4	~19	1,200	3,000	140	0.4	~19	1,200	3,700
		210	0.3	~19	1,000	2,700	210	0.3	~19	1,000	3,400
Hardened die steel (SKD61, DAC, DHA) 42-52HRC	JC8118 (JC8050)	~90	0.4	~19	900	1,800	~90	0.4	~19	900	2,250
		140	0.3	~19	900	1,800	140	0.3	~19	900	2,250
		210	—	—	—	—	210	—	—	—	—
Hardened die steel (SKD11, SLD, DC11) 55-62HRC	JC8118 EPMWType	~90	0.15	~19	400	240	~90	0.15	~19	400	300
		140	0.1	~19	400	240	140	0.1	~19	400	300
		210	—	—	—	—	210	—	—	—	—
Gery & Nodular cast iron (FC, FCD) below 300HB	JC8118 (JC7560)	~90	0.8	~19	1,900	6,400	~90	0.8	~19	1,900	8,000
		140	0.6	~19	1,900	5,800	140	0.6	~19	1,900	7,200
		210	0.5	~19	1,600	4,800	210	0.5	~19	1,600	6,000
Stainless steel (SUS304) below 250HB	JC8050 (JC7560)	~90	0.8	~19	2,000	5,450	~90	0.8	~19	2,000	6,800
		140	0.6	~19	2,000	5,200	140	0.6	~19	2,000	6,500
		210	0.35	~19	1,900	4,950	210	0.35	~19	1,900	6,200
Titanium alloy (Ti-6Al-4V)	DS150 (DS118) (JC8050)	~90	0.5	~19	750	1,200	~90	0.5	~19	750	1,500
		140	0.3	~19	750	1,200	140	0.3	~19	750	1,500
		210	0.2	~19	750	1,200	210	0.2	~19	750	1,500
Heat resistant alloy (INCO718)	JC8118 (DS118) (DS150)	~90	0.5	~19	400	480	~90	0.5	~19	400	600
		140	0.3	~19	400	480	140	0.3	~19	400	600
		210	0.2	~19	400	480	210	0.2	~19	400	600

Note

1. Please adjust cutting conditions according to machine rigidity or work rigidity.
2. In case of chatter occurring, recommended to reduce ap or rpm and keep feed per tooth.
3. ap should be reduced when using on low rigidity machine.
4. Use air blow.
5. When using ZPMT100320ZER-PL insert for High feed milling, reduce cutting conditions above by 10-30%.
6. When using Endmill type, reduce cutting conditions above by 10-20%.

QM MAX**MQX/QXP Type**

■ Recommended cutting conditions

● MQX Type (EPMT/W insert) + MSN shank

①

Material	Grade	Tool dia.(mm)									
		30/32/35					32/35				
		5N					6N				
		ℓ (mm)	a_p (mm)	a_e (mm)	n (min ⁻¹)	V_f (mm/min)	ℓ (mm)	a_p (mm)	a_e (mm)	n (min ⁻¹)	V_f (mm/min)
Carbon steel (S50C, S55C) below 250HB	JC7560	~100	0.8	~25	1,900	6,350	~100	0.8	~25	1,900	7,600
	(JC8050)	150	0.6	~25	1,800	6,000	150	0.6	~25	1,800	7,200
	(JC8118)	210	0.4	~25	1,500	5,000	210	0.4	~25	1,500	6,000
Tool & die steel (SKD61, SKD11) below 255HB	JC7560	~100	0.8	~25	1,900	6,350	~100	0.8	~25	1,900	7,600
	(JC8050)	150	0.6	~25	1,800	6,000	150	0.6	~25	1,800	7,200
	(JC8118)	210	0.4	~25	1,500	5,000	210	0.4	~25	1,500	6,000
Mold steel (HPM7, PX5, P20) 30-36 HRC	JC8118	~100	0.8	~25	1,900	6,350	~100	0.8	~25	1,900	7,600
	(JC7560)	150	0.6	~25	1,800	6,000	150	0.6	~25	1,800	7,200
	(JC8050)	210	0.4	~25	1,500	5,000	210	0.4	~25	1,500	6,000
Mold steel (NAK80, HPM1, P21) 38-43HRC	JC8118	~100	0.6	~25	950	3,200	~100	0.6	~25	950	3,800
	(JC7560)	150	0.4	~25	950	3,200	150	0.4	~25	950	3,800
	(JC8050)	210	0.3	~25	800	2,650	210	0.3	~25	800	3,200
Hardened die steel (SKD61, DAC, DHA) 42-52HRC	JC8118	~100	0.4	~25	700	1,750	~100	0.4	~25	700	2,100
	(JC8050)	150	0.3	~25	700	1,750	150	0.3	~25	700	2,100
		210	—	—	—	—	210	—	—	—	—
Hardened die steel (SKD11, SLD, DC11) 55-62HRC	JC8118	~100	0.15	~25	300	250	~100	0.15	~25	300	300
	(JC8050)	150	0.1	~25	300	250	150	0.1	~25	300	300
	EPMTType	210	—	—	—	—	210	—	—	—	—
Grey & Nodular cast iron (FC, FCD) below 300HB	JC8118	~100	1	~25	1,500	6,250	~100	1	~25	1,500	7,500
	(JC7560)	150	0.8	~25	1,500	5,750	150	0.8	~25	1,500	6,900
		210	0.6	~25	1,250	4,850	210	0.6	~25	1,250	5,800
Stainless steel (SUS304) below 250HB	JC8050	~100	0.8	~25	1,700	5,700	~100	0.8	~25	1,700	6,800
	(JC7560)	150	0.6	~25	1,600	5,350	150	0.6	~25	1,600	6,400
		210	0.35	~25	1,500	5,000	210	0.35	~25	1,500	6,000
Titanium alloy (Ti-6Al-4V)	DS150	~100	0.5	~25	600	1,250	~100	0.5	~25	600	1,500
	(DS118)	150	0.3	~25	600	1,250	150	0.3	~25	600	1,500
	(JC8050)	210	0.2	~25	600	1,250	210	0.2	~25	600	1,500
Heat resistant alloy (INCO718)	JC8118	~100	0.5	~25	300	500	~100	0.5	~25	300	580
	(DS118)	150	0.3	~25	300	500	150	0.3	~25	300	580
	(DS150)	210	0.2	~25	300	500	210	0.2	~25	300	580

Note

1. Please adjust cutting conditions according to machine rigidity or work rigidity.
2. In case of chatter occurring, recommended to reduce a_p or rpm and keep feed per tooth.
3. a_p should be reduced when using on low rigidity machine.
4. Use air blow.
5. When using ZPMT100320ZER-PL insert for High feed milling, reduce cutting conditions above by 10-30%.
6. When using Endmill type, reduce cutting conditions above by 10-20%.

QM MAX **MQX/QXP Type**

- Recommended cutting conditions
- MQX Type (EPMT/W insert) + MSN shank

1

Material	Grade	Tool dia.(mm)									
		40/42					40				
		6N					7N				
		ℓ (mm)	ap (mm)	ae (mm)	n (min ⁻¹)	Vf (mm/min)	ℓ (mm)	ap (mm)	ae (mm)	n (min ⁻¹)	Vf (mm/min)
Carbon steel (S50C, S55C) below 250HB	JC7560	~100	0.8	~32	1,500	6,300	~100	0.8	~32	1,500	7,500
	(JC8050)	150	0.6	~32	1,400	5,900	150	0.6	~32	1,400	7,000
	(JC8118)	210	0.4	~32	1,200	5,000	210	0.4	~32	1,200	6,000
Tool & die steel (SKD61, SKD11) below 255HB	JC7560	~100	0.8	~32	1,500	6,300	~100	0.8	~32	1,500	7,500
	(JC8050)	150	0.6	~32	1,400	5,900	150	0.6	~32	1,400	7,000
	(JC8118)	210	0.4	~32	1,200	5,000	210	0.4	~32	1,200	6,000
Mold steel (HPM7, PX5, P20) 30-36 HRC	JC8118	~100	0.8	~32	1,500	6,300	~100	0.8	~32	1,500	7,500
	(JC7560)	150	0.6	~32	1,400	5,900	150	0.6	~32	1,400	7,000
	(JC8050)	210	0.4	~32	1,200	5,000	210	0.4	~32	1,200	6,000
Mold steel (NAK80, HPM1, P21) 38-43HRC	JC8118	~100	0.6	~32	750	3,000	~100	0.6	~32	750	3,500
	(JC8050)	150	0.4	~32	750	3,000	150	0.4	~32	750	3,500
		210	0.3	~32	620	2,500	210	0.3	~32	620	2,900
Hardened die steel (SKD61, DAC, DHA) 42-52HRC	JC8118	~100	0.4	~32	550	1,650	~100	0.4	~32	550	1,900
	(JC8050)	150	0.3	~32	550	1,650	150	0.3	~32	550	1,900
		210	—	—	—	—	210	—	—	—	—
Hardened die steel (SKD11, SLD, DC11) 55-62HRC	JC8118	~100	0.15	~32	250	240	~100	0.15	~32	250	280
	EPMTType	150	0.1	~32	250	240	150	0.1	~32	250	280
		210	—	—	—	—	210	—	—	—	—
Gery & Nodular cast iron (FC, FCD) below 300HB	JC8118	~100	1	~32	1,200	6,150	~100	1	~32	1,200	7,200
	(JC7560)	150	0.8	~32	1,200	5,650	150	0.8	~32	1,200	6,600
		210	0.6	~32	1,000	4,700	210	0.6	~32	1,000	5,500
Stainless steel (SUS304) below 250HB	JC8050	~100	0.8	~32	1,350	5,850	~100	0.8	~32	1,350	6,800
	(JC7560)	150	0.6	~32	1,300	5,550	150	0.6	~32	1,300	6,500
		210	0.35	~32	1,200	5,150	210	0.35	~32	1,200	6,000
Titanium alloy (Ti-6Al-4V)	DS150	~100	0.5	~32	480	1,150	~100	0.5	~32	480	1,350
	(DS118)	150	0.3	~32	480	1,150	150	0.3	~32	480	1,350
	(JC8050)	210	0.2	~32	480	1,150	210	0.2	~32	480	1,350
Heat resistant alloy (INCO718)	JC8118	~100	0.5	~32	250	450	~100	0.5	~32	250	520
	(DS118)	150	0.3	~32	250	450	150	0.3	~32	250	520
	(DS150)	210	0.2	~32	250	450	210	0.2	~32	250	520

Note

1. Please adjust cutting conditions according to machine rigidity or work rigidity.
2. In case of chatter occurring, recommended to reduce ap or rpm and keep feed per tooth.
3. ap should be reduced when using on low rigidity machine.
4. Use air blow.
5. When using ZPMT100320ZER-PL insert for High feed milling, reduce cutting conditions above by 10-30%.
6. When using Endmill type, reduce cutting conditions above by 10-20%.

QM MAX**MQX/QXP Type**

■ Recommended cutting conditions

● QXP Type (EPMT/W insert)

①

Material	Grade	protrusion length ℓ (mm)	Tool dia.(mm)							
			40							
			6N				7N			
			a _p (mm)	a _e (mm)	n (min ⁻¹)	V _f (mm/min)	a _p (mm)	a _e (mm)	n (min ⁻¹)	V _f (mm/min)
Carbon steel (S50C, S55C) below 250HB	JC7560 (JC8050) (JC8118)	~150	0.8	~32	1,250	6,000	0.8	~32	1,250	7,000
		200	0.6	~32	1,100	5,300	0.6	~32	1,100	6,200
		250	0.5	~32	1,000	4,800	0.5	~32	1,000	5,600
		300	—	—	—	—	—	—	—	—
		350	—	—	—	—	—	—	—	—
Tool & die steel (SKD61, SKD11) below 255HB	JC7560 (JC8050) (JC8118)	~150	0.8	~32	1,250	6,000	0.8	~32	1,250	7,000
		200	0.6	~32	1,100	5,300	0.6	~32	1,100	6,200
		250	0.5	~32	1,000	4,800	0.5	~32	1,000	5,600
		300	—	—	—	—	—	—	—	—
		350	—	—	—	—	—	—	—	—
Mold steel (HPM7, PX5, P20) 30-36 HRC	JC8118 (JC7560) (JC8050)	~150	0.8	~32	1,250	6,000	0.8	~32	1,250	7,000
		200	0.6	~32	1,100	5,300	0.6	~32	1,100	6,200
		250	0.5	~32	1,000	4,800	0.5	~32	1,000	5,600
		300	—	—	—	—	—	—	—	—
		350	—	—	—	—	—	—	—	—
Mold steel (NAK80, HPM1, P21) 38-43HRC	JC8118 (JC8050)	~150	0.6	~32	680	2,850	0.6	~32	680	3,300
		200	0.4	~32	640	2,650	0.4	~32	640	3,100
		250	0.3	~32	600	2,500	0.3	~32	600	2,900
		300	—	—	—	—	—	—	—	—
		350	—	—	—	—	—	—	—	—
Hardened die steel (SKD61, DAC, DHA) 42-52HRC	JC8118 (JC8050)	~150	0.4	~32	520	1,550	0.4	~32	520	1,800
		200	0.2	~32	520	1,550	0.2	~32	520	1,800
		250	—	—	—	—	—	—	—	—
		300	—	—	—	—	—	—	—	—
		350	—	—	—	—	—	—	—	—
Hardened die steel (SKD11, SLD, DC11) 55-62HRC	JC8118 EPMWType	~150	0.15	~32	240	230	0.15	~32	240	270
		200	0.1	~32	220	210	0.1	~32	220	250
		250	—	—	—	—	—	—	—	—
		300	—	—	—	—	—	—	—	—
		350	—	—	—	—	—	—	—	—
Grey & Nodular Cast iron (FC, FCD) below 300HB	JC8118 (JC7560)	~150	0.8	~32	1,100	6,600	0.8	~32	1,100	7,700
		200	0.6	~32	1,000	6,000	0.6	~32	1,000	7,000
		250	0.5	~32	900	5,400	0.5	~32	900	6,300
		300	—	—	—	—	—	—	—	—
		350	—	—	—	—	—	—	—	—
Stainless steel (SUS304) below 250HB	JC8050 (JC7560)	~150	0.6	~32	1,200	5,400	0.6	~32	1,200	6,300
		200	0.4	~32	1,100	4,950	0.4	~32	1,100	5,800
		250	0.3	~32	1,000	4,450	0.3	~32	1,000	5,200
		300	—	—	—	—	—	—	—	—
		350	—	—	—	—	—	—	—	—
Titanium alloy (Ti-6Al-4V)	DS150 (DS118) (JC8050)	~150	0.6	~32	480	1,150	0.6	~32	480	1,350
		200	0.4	~32	440	1,050	0.4	~32	440	1,230
		250	0.3	~32	440	1,050	0.3	~32	440	1,230
		300	—	—	—	—	—	—	—	—
		350	—	—	—	—	—	—	—	—
Heat resistant alloy (INCO718)	JC8118 (DS118) (DS150)	~150	0.6	~32	240	430	0.6	~32	240	500
		200	0.4	~32	200	360	0.4	~32	200	420
		250	0.3	~32	200	360	0.3	~32	200	420
		300	—	—	—	—	—	—	—	—
		350	—	—	—	—	—	—	—	—

QM MAX

MQX/QXP Type

■ Recommended cutting conditions

● QXP Type (EPMT/W insert)

①

Material	Grade	protrusion length (mm)	Tool dia. (mm)							
			50				50/52			
			7N				8N			
			ap (mm)	ae (mm)	n (min ⁻¹)	Vf (mm/min)	ap (mm)	ae (mm)	n (min ⁻¹)	Vf (mm/min)
Carbon steel (S50C, S55C) below 250HB	JC7560 (JC8050) (JC8118)	~150	1	~40	1,000	6,300	1	~40	1,000	7,200
		200	0.8	~40	1,000	5,950	0.8	~40	1,000	6,800
		250	0.6	~40	900	5,350	0.6	~40	900	6,100
		300	0.5	~40	800	4,750	0.5	~40	800	5,450
		350	0.4	~40	800	4,750	0.4	~40	800	5,450
Tool & die steel (SKD61, SKD11) below 255HB	JC7560 (JC8050) (JC8118)	~150	1	~40	1,000	6,300	1	~40	1,000	7,200
		200	0.8	~40	1,000	5,950	0.8	~40	1,000	6,800
		250	0.6	~40	900	5,350	0.6	~40	900	6,100
		300	0.5	~40	800	4,750	0.5	~40	800	5,450
		350	0.4	~40	800	4,750	0.4	~40	800	5,450
Mold steel (HPM7, PX5, P20) 30-36 HRC	JC8118 (JC7560) (JC8050)	~150	1	~40	1,000	6,300	1	~40	1,000	7,200
		200	0.8	~40	1,000	5,950	0.8	~40	1,000	6,800
		250	0.6	~40	900	5,350	0.6	~40	900	6,100
		300	0.5	~40	800	4,750	0.5	~40	800	5,450
		350	0.4	~40	800	4,750	0.4	~40	800	5,450
Mold steel (NAK80, HPM1, P21) 38-43HRC	JC8118 (JC8050)	~150	0.8	~40	540	2,600	0.8	~40	540	3,000
		200	0.6	~40	540	2,600	0.6	~40	540	3,000
		250	0.4	~40	510	2,500	0.4	~40	510	2,850
		300	0.3	~40	480	2,350	0.3	~40	480	2,700
		350	0.3	~40	480	2,000	0.3	~40	480	2,300
Hardened die steel (SKD61, DAC, DHA) 42-52HRC	JC8118 (JC8050)	~150	0.6	~40	400	1,400	0.6	~40	400	1,600
		200	0.4	~40	400	1,400	0.4	~40	400	1,600
		250	0.2	~40	400	1,400	0.2	~40	400	1,600
		300	—	—	—	—	—	—	—	—
		350	—	—	—	—	—	—	—	—
Hardened die steel (SKD11, SLD, DC11) 55-62HRC	JC8118 EPMTType	~150	0.15	~40	190	210	0.15	~40	190	240
		200	0.15	~40	170	190	0.15	~40	170	220
		250	0.1	~40	170	190	0.1	~40	170	220
		300	—	—	—	—	—	—	—	—
		350	—	—	—	—	—	—	—	—
Gery & Nodular Cast iron (FC, FCD) below 300HB	JC8118 (JC7560)	~150	1	~40	900	7,500	1	~40	900	8,600
		200	0.8	~40	900	6,300	0.8	~40	900	7,200
		250	0.6	~40	850	5,950	0.6	~40	850	6,800
		300	0.5	~40	800	5,600	0.5	~40	800	6,400
		350	0.4	~40	800	5,600	0.4	~40	800	6,400
Stainless steel (SUS304) below 250HB	JC8050 (JC7560)	~150	0.8	~40	950	5,600	0.8	~40	950	6,400
		200	0.6	~40	950	5,000	0.6	~40	950	5,700
		250	0.4	~40	900	4,700	0.4	~40	900	5,400
		300	0.3	~40	900	4,700	0.3	~40	900	5,400
		350	0.3	~40	850	4,450	0.3	~40	850	5,100
Titanium alloy (Ti-6Al-4V)	DS150 (DS118) (JC8050)	~150	0.8	~40	380	1,050	0.8	~40	380	1,220
		200	0.6	~40	380	1,050	0.6	~40	380	1,220
		250	0.4	~40	350	980	0.4	~40	350	1,120
		300	0.3	~40	350	980	0.3	~40	350	1,120
		350	0.3	~40	320	890	0.3	~40	320	1,020
Heat resistant alloy (INCO718)	JC8118 (DS118) (DS150)	~150	0.8	~40	190	390	0.8	~40	190	450
		200	0.6	~40	190	390	0.6	~40	190	450
		250	0.4	~40	160	330	0.4	~40	160	380
		300	0.3	~40	160	330	0.3	~40	160	380
		350	0.3	~40	130	270	0.3	~40	130	310

QM MAX**MQX/QXP Type**

■ Recommended cutting conditions

● QXP Type (EPMT/W insert) ①

Material	Grade	protrusion length l (mm)	Tool dia.(mm)			
			63/66			
			8N			
			a_p (mm)	a_e (mm)	n (min^{-1})	V_f (mm/min)
Carbon steel (S50C, S55C) below 250HB	JC7560 (JC8050) (JC8118)	~200	1	~50	800	5,750
		250	0.8	~50	800	5,450
		300	0.6	~50	720	4,900
		350	0.5	~50	640	4,350
		400	0.4	~50	640	4,350
Tool & die steel (SKD61, SKD11) below 255HB	JC7560 (JC8050) (JC8118)	~200	1	~50	800	5,750
		250	0.8	~50	800	5,450
		300	0.6	~50	720	4,900
		350	0.5	~50	640	4,350
		400	0.4	~50	640	4,350
Mold steel (HPM7, PX5, P20) 30-36 HRC	JC8118 (JC7560) (JC8050)	~200	1	~50	800	5,750
		250	0.8	~50	800	5,450
		300	0.6	~50	720	4,900
		350	0.5	~50	640	4,350
		400	0.4	~50	640	4,350
Mold steel (NAK80, HPM1, P21) 38-43HRC	JC8118 (JC8050)	~200	0.8	~50	430	2,400
		250	0.6	~50	430	2,400
		300	0.4	~50	410	2,300
		350	0.3	~50	370	2,100
		400	0.3	~50	370	1,800
Hardened die steel (SKD61, DAC, DHA) 42-52HRC	JC8118 (JC8050)	~200	0.6	~50	320	1,300
		250	0.4	~50	320	1,300
		300	0.2	~50	320	1,300
		350	—	—	—	—
		400	—	—	—	—
Hardened die steel (SKD11, SLD, DC11) 55-62HRC	JC8118 EPMWType	~200	0.15	~50	150	190
		250	0.15	~50	130	170
		300	0.1	~50	130	170
		350	—	—	—	—
		400	—	—	—	—
Gery & Nodular cast iron (FC, FCD) below 300HB	JC8118 (JC7560)	~200	1	~50	720	6,900
		250	0.8	~50	720	5,750
		300	0.6	~50	680	5,450
		350	0.5	~50	640	5,100
		400	0.4	~50	640	5,100
Stainless steel (SUS304) below 250HB	JC8050 (JC7560)	~200	0.8	~50	750	5,050
		250	0.6	~50	750	4,500
		300	0.4	~50	710	4,250
		350	0.3	~50	710	4,250
		400	0.3	~50	670	4,000
Titanium alloy (Ti-6Al-4V)	DS150 (DS118) (JC8050)	~200	0.8	~50	300	960
		250	0.6	~50	300	960
		300	0.4	~50	280	900
		350	0.3	~50	280	900
		400	0.3	~50	250	800
Heat resistant alloy (INCO718)	JC8118 (DS118) (DS150)	~200	0.8	~50	150	350
		250	0.6	~50	150	350
		300	0.4	~50	130	310
		350	0.3	~50	130	310
		400	0.3	~50	100	240

Note

1. Please adjust cutting conditions according to machine rigidity or work rigidity.
2. In case of chatter occurring, recommended to reduce a_p or rpm and keep feed per tooth.
3. a_p should be reduced when using on low rigidity machine.
4. Use air blow.
5. When using ZPMT100320ZER-PL insert for High feed milling, reduce cutting conditions by 10-30%.

QM MAX **MQX/QXP Type**

- Recommended cutting conditions
- **MQX Type (EPHW insert) + MSN shank**

2

Material	Grade	Tool dia.(mm)														
		16 / 17					20					20 / 21				
		2N					3N					4N				
		r (mm)	ap (mm)	ae (mm)	n (min ⁻¹)	Vf (mm/min)	r (mm)	ap (mm)	ae (mm)	n (min ⁻¹)	Vf (mm/min)	r (mm)	ap (mm)	ae (mm)	n (min ⁻¹)	Vf (mm/min)
Hardened die steel (SKD61, DAC, DHA) 42-52HRC	JC8118	~70	0.30	~10	1,790	2,860	~80	0.30	~14	1,430	3,430	~80	0.30	~14	1,430	4,570
		100	0.25	~10	1,610	2,060	120	0.25	~14	1,290	2,480	120	0.25	~14	1,290	3,300
		130	0.20	~10	1,430	1,370	160	0.20	~14	1,140	1,640	160	0.20	~14	1,140	2,190
Hardened die steel (SKD11, SLD, DC11) 55-62HRC	DH102	~70	0.20	~10	1,590	950	~80	0.20	~14	1,270	1,140	~80	0.20	~14	1,270	1,520
		100	0.15	~10	1,430	770	120	0.15	~14	1,140	920	120	0.15	~14	1,140	1,230
		130	0.10	~10	1,270	610	160	0.10	~14	1,020	730	160	0.10	~14	1,020	980

Material	Grade	Tool dia.(mm)									
		25 / 26					25 / 26 / 28				
		4N					5N				
		r (mm)	ap (mm)	ae (mm)	n (min ⁻¹)	Vf (mm/min)	r (mm)	ap (mm)	ae (mm)	n (min ⁻¹)	Vf (mm/min)
Hardened die steel (SKD61, DAC, DHA) 42-52HRC	JC8118	~100	0.30	~18	1,150	3,680	~100	0.30	~18	1,150	4,600
		150	0.25	~18	1,040	2,660	150	0.25	~18	1,040	3,330
		200	0.20	~18	920	1,770	200	0.20	~18	920	2,210
Hardened die steel (SKD11, SLD, DC11) 55-62HRC	DH102	~100	0.20	~18	1,020	1,220	~100	0.20	~18	1,020	1,530
		150	0.15	~18	920	990	150	0.15	~18	920	1,240
		200	0.10	~18	820	790	200	0.10	~18	820	980

Note

1. Please adjust cutting conditions according to machine rigidity or work rigidity.
2. In case of chatter occurring, recommended to reduce ap or rpm and keep feed per tooth.
3. ap should be reduced when using on low rigidity machine.
4. Use air blow.

QM MAX**MQX/QXP Type**

■ Recommended cutting conditions

● MQX Type (EPHW insert) + MSN shank

②

Material	Grade	Tool dia.(mm)									
		30 / 32 / 35					32 / 35				
		5N					6N				
		r (mm)	a _p (mm)	a _e (mm)	n (min ⁻¹)	V _f (mm/min)	r (mm)	a _p (mm)	a _e (mm)	n (min ⁻¹)	V _f (mm/min)
Hardened die steel (SKD61, DAC, DHA) 42-52HRC	JC8118	~130	0.30	~24	900	3,600	~130	0.30	~24	900	4,320
		190	0.25	~24	810	2,590	190	0.25	~24	810	3,110
		250	0.20	~24	720	1,730	250	0.20	~24	720	2,070
Hardened die steel (SKD11, SLD, DC11) 55-62HRC	DH102	~130	0.20	~24	800	1,200	~130	0.20	~24	800	1,440
		190	0.15	~24	720	970	190	0.15	~24	720	1,160
		250	0.10	~24	640	770	250	0.10	~24	640	920

Material	Grade	Tool dia.(mm)									
		40 / 42					40				
		6N					7N				
		r (mm)	a _p (mm)	a _e (mm)	n (min ⁻¹)	V _f (mm/min)	r (mm)	a _p (mm)	a _e (mm)	n (min ⁻¹)	V _f (mm/min)
Hardened die steel (SKD61, DAC, DHA) 42-52HRC	JC8118	~130	0.30	~32	720	3,460	~130	0.30	~32	720	4,030
		190	0.25	~32	650	2,500	190	0.25	~32	650	2,910
		250	0.20	~32	580	1,670	250	0.20	~32	580	1,950
Hardened die steel (SKD11, SLD, DC11) 55-62HRC	DH102	~130	0.20	~32	640	1,150	~130	0.20	~32	640	1,340
		190	0.15	~32	580	940	190	0.15	~32	580	1,100
		250	0.10	~32	510	740	250	0.10	~32	510	860

Note

1. Please adjust cutting conditions according to machine rigidity or work rigidity.
2. In case of chatter occurring, recommended to reduce a_p or rpm and keep feed per tooth.
3. a_p should be reduced when using on low rigidity machine.
4. Use air blow.

QM MAX
MQX/QXP Type
■ Recommended cutting conditions
● QXP Type (EPHW insert)
2

Material	Grade	Tool dia.(mm)									
		40									
		6N					7N				
		r (mm)	a_p (mm)	a_e (mm)	n (min ⁻¹)	V_f (mm/min)	r (mm)	a_p (mm)	a_e (mm)	n (min ⁻¹)	V_f (mm/min)
Hardened die steel (SKD61, DAC, DHA) 42-52HRC	JC8118	~100	0.30	~32	720	3,460	~100	0.30	~32	720	4,030
		150	0.25	~32	650	2,500	150	0.25	~32	650	2,910
		200	0.20	~32	580	1,670	200	0.20	~32	580	1,950
		250	0.10	~32	580	1,670	250	0.10	~32	580	1,950
Hardened die steel (SKD11, SLD, DC11) 55-62HRC	DH102	~100	0.20	~32	640	1,150	~100	0.20	~32	640	1,340
		150	0.15	~32	580	940	150	0.15	~32	580	1,100
		200	0.10	~32	510	740	200	0.10	~32	510	860
		250	-	-	-	-	250	-	-	-	-

Material	Grade	Tool dia.(mm)									
		50					50 / 52				
		7N					8N				
		r (mm)	a_p (mm)	a_e (mm)	n (min ⁻¹)	V_f (mm/min)	r (mm)	a_p (mm)	a_e (mm)	n (min ⁻¹)	V_f (mm/min)
Hardened die steel (SKD61, DAC, DHA) 42-52HRC	JC8118	~150	0.30	~40	570	3,190	~100	0.30	~40	570	3,650
		200	0.25	~40	510	2,280	150	0.25	~40	510	2,610
		250	0.20	~40	460	1,550	200	0.20	~40	460	1,770
		300	0.10	~40	460	1,550	250	0.10	~40	460	1,770
Hardened die steel (SKD11, SLD, DC11) 55-62HRC	DH102	~150	0.20	~40	510	1,070	~100	0.20	~40	510	1,220
		200	0.15	~40	460	870	150	0.15	~40	460	990
		250	0.10	~40	410	690	200	0.10	~40	410	790
		300	-	-	-	-	250	-	-	-	-
						300					

Material	Grade	Tool dia.(mm)									
		63 / 66									
		8N									
		r (mm)	a_p (mm)	a_e (mm)	n (min ⁻¹)	V_f (mm/min)					
Hardened die steel (SKD61, DAC, DHA) 42-52HRC	JC8118	~200	0.30	~50	450	2,880					
		250	0.25	~50	410	2,100					
		300	0.20	~50	360	1,380					
		350	0.10	~50	360	1,380					
Hardened die steel (SKD11, SLD, DC11) 55-62HRC	DH102	~200	0.20	~50	400	960					
		250	0.15	~50	360	780					
		300	0.10	~50	320	610					
		350	-	-	-	-					

Note

1. Please adjust cutting conditions according to machine rigidity or work rigidity.
2. In case of chatter occurring, recommended to reduce a_p or rpm and keep feed per tooth.
3. a_p should be reduced when using on low rigidity machine.
4. Use air blow.

QM MAX**MQX/QXP Type**

■ Recommended cutting conditions

● MQX Type (ZPMT-PL /NL/ SL insert)

3

Material	Chipbreaker	Grade	Tool dia. (mm)														
			16 / 17					20					20 / 21				
			2N					3N					4N				
			r (mm)	a _p (mm)	a _p ×a _e (mm ²)	n (min ⁻¹)	V _f (mm/min)	r (mm)	a _p (mm)	a _p ×a _e (mm ²)	n (min ⁻¹)	V _f (mm/min)	r (mm)	a _p (mm)	a _p ×a _e (mm ²)	n (min ⁻¹)	V _f (mm/min)
Carbon steel (S50C, S55C) below 250HB	PL	JC8050 (JC8118) (CX75)	~80	≤5.0	≤12.8	3,180	950	~100	≤5.0	≤16.0	2,550	1,150	~100	≤5.0	≤16.0	2,550	1,530
			120	≤3.0	≤6.4	2,860	770	150	≤3.0	≤8.0	2,300	930	150	≤3.0	≤8.0	2,300	1,240
			160	≤2.0	≤3.2	2,540	610	190	≤2.0	≤4.0	2,040	730	190	≤2.0	≤4.0	2,040	980
Tool & die steel (SKD61, SKD11) below 255HB	PL	JC8050 (JC8118)	~80	≤5.0	≤12.8	2,980	890	~100	≤5.0	≤16.0	2,390	1,080	~100	≤5.0	≤16.0	2,390	1,430
			120	≤3.0	≤6.4	2,680	720	150	≤3.0	≤8.0	2,150	870	150	≤3.0	≤8.0	2,150	1,160
			160	≤2.0	≤3.2	2,380	570	190	≤2.0	≤4.0	1,910	690	190	≤2.0	≤4.0	1,910	920
Mold steel (HPM7, PX5, P20) 30-36 HRC	PL	JC8118 (JC8050)	~80	≤5.0	≤12.8	2,980	890	~100	≤5.0	≤16.0	2,390	1,080	~100	≤5.0	≤16.0	2,390	1,430
			120	≤3.0	≤6.4	2,680	720	150	≤3.0	≤8.0	2,150	870	150	≤3.0	≤8.0	2,150	1,160
			160	≤2.0	≤3.2	2,380	570	190	≤2.0	≤4.0	1,910	690	190	≤2.0	≤4.0	1,910	920
Mold steel (NAK80, HPM1, P21) 38-43HRC	PL	JC8118 (JC8050)	~80	≤4.0	≤9.6	2,390	570	~100	≤4.0	≤12.0	1,910	690	~100	≤4.0	≤12.0	1,910	920
			120	≤2.5	≤4.8	2,150	470	150	≤2.5	≤6.0	1,720	570	150	≤2.5	≤6.0	1,720	760
			160	≤2.0	≤2.4	1,910	380	190	≤2.0	≤3.0	1,530	460	190	≤2.0	≤3.0	1,530	610
Hardened die steel (SKD61, DAC, DHA) 42-52HRC	PL	JC8118 (DH102)	~80	≤3.5	≤8.0	1,990	480	~100	≤3.5	≤10.0	1,590	570	~100	≤3.5	≤10.0	1,590	760
			120	≤2.5	≤4.0	1,790	390	150	≤2.5	≤5.0	1,430	460	150	≤2.5	≤5.0	1,430	620
			160	≤1.2	≤2.0	1,590	300	190	≤1.2	≤2.5	1,270	360	190	≤1.2	≤2.5	1,270	480
Hardened die steel (SKD11, SLD, DC11) 55-62HRC	PL	DH102	~80	≤2.5	≤6.4	1,390	280	~100	≤2.5	≤8.0	1,110	330	~100	≤2.5	≤8.0	1,110	440
			120	≤1.5	≤3.2	1,250	230	150	≤1.5	≤4.0	1,000	270	150	≤1.5	≤4.0	1,000	360
			160	-	-	-	-	190	-	-	-	-	190	-	-	-	-
Grey & Nodular cast iron (FC, FCD) below 300HB	PL	JC8118 (DH102)	~80	≤5.0	≤16.0	2,980	1,190	~100	≤5.0	≤20.0	2,390	1,430	~100	≤5.0	≤20.0	2,390	1,910
			120	≤4.0	≤8.0	2,680	960	150	≤4.0	≤10.0	2,150	1,160	150	≤4.0	≤10.0	2,150	1,550
			160	≤3.0	≤4.0	2,380	760	190	≤3.0	≤5.0	1,910	920	190	≤3.0	≤5.0	1,910	1,220
Stainless steel (SUS304) below 250HB	PL (SL)	JC8050 (JC8118) (JC7518)	~80	≤5.0	≤12.8	2,980	890	~100	≤5.0	≤16.0	2,390	1,080	~100	≤5.0	≤16.0	2,390	1,430
			120	≤3.0	≤6.4	2,680	720	150	≤3.0	≤8.0	2,150	870	150	≤3.0	≤8.0	2,150	1,160
			160	≤2.0	≤3.2	2,380	570	190	≤2.0	≤4.0	1,910	690	190	≤2.0	≤4.0	1,910	920
Titanium alloy (Ti-6Al-4V)	SL	DS118 (JC7518)	~80	≤5.0	≤9.6	1,190	360	~100	≤5.0	≤12.0	950	430	~100	≤5.0	≤12.0	950	570
			120	≤3.0	≤4.8	1,070	290	150	≤3.0	≤6.0	860	350	150	≤3.0	≤6.0	860	460
			160	≤2.0	≤2.4	950	230	190	≤2.0	≤3.0	760	270	190	≤2.0	≤3.0	760	360
Heat resistant alloy (INCO718)	SL	DS118 (JC7518)	~80	≤5.0	≤9.6	600	180	~100	≤5.0	≤12.0	480	220	~100	≤5.0	≤12.0	480	290
			120	≤3.0	≤4.8	540	140	150	≤3.0	≤6.0	430	170	150	≤3.0	≤6.0	430	230
			160	≤2.0	≤2.4	480	110	190	≤2.0	≤3.0	380	140	190	≤2.0	≤3.0	380	180
Aluminium alloy below 50-110HB	NL	FC18	~80	≤5.0	≤32.0	12,000	4,800	~100	≤5.0	≤40.0	9,550	5,730	~100	≤5.0	≤40.0	9,550	7,640
			120	≤4.0	≤16.0	9,000	3,240	150	≤4.0	≤20.0	7,160	3,870	150	≤4.0	≤20.0	7,160	5,160
			160	≤3.0	≤8.0	6,000	1,920	190	≤3.0	≤10.0	4,780	2,290	190	≤3.0	≤10.0	4,780	3,060

Note

1. Please adjust cutting conditions according to machine rigidity or work rigidity.
2. In case of chatter occurring, recommended to reduce a_p or rpm and keep feed per tooth.
3. a_p should be reduced when using on low rigidity machine.
4. Use air blow.
5. Please scan QR code below for cutting conditions when using ZPMT-PL/NL/SL for side & bottom finishing.



QM MAX**MQX/QXP Type**

■ Recommended cutting conditions

● MQX Type (ZPMT-PL /NL/ SL insert)

3

Material	Chipbreaker	Grade	Tool dia.(mm)									
			25 / 26					25 / 26 / 28				
			4N					5N				
			r (mm)	ap (mm)	ap×ae (mm ²)	n (min ⁻¹)	Vf (mm/min)	r (mm)	ap (mm)	ap×ae (mm ²)	n (min ⁻¹)	Vf (mm/min)
Carbon steel (S50C, S55C) below 250HB	PL	JC8050 (JC8118) (CX75)	~120	≤5.0	≤20.0	2,040	1,220	~120	≤5.0	≤20.0	2,040	1,530
			190	≤3.0	≤10.0	1,840	990	190	≤3.0	≤10.0	1,840	1,240
			235	≤2.0	≤5.0	1,630	780	235	≤2.0	≤5.0	1,630	980
Tool & die steel (SKD61, SKD11) below 255HB	PL	JC8050 (JC8118)	~120	≤5.0	≤20.0	1,910	1,150	~120	≤5.0	≤20.0	1,910	1,430
			190	≤3.0	≤10.0	1,720	930	190	≤3.0	≤10.0	1,720	1,160
			235	≤2.0	≤5.0	1,530	730	235	≤2.0	≤5.0	1,530	920
Mold steel (HPM7, PX5, P20) 30-36 HRC	PL	JC8118 (JC8050)	~120	≤5.0	≤20.0	1,910	1,150	~120	≤5.0	≤20.0	1,910	1,430
			190	≤3.0	≤10.0	1,720	930	190	≤3.0	≤10.0	1,720	1,160
			235	≤2.0	≤5.0	1,530	730	235	≤2.0	≤5.0	1,530	920
Mold steel (NAK80, HPM1, P21) 38-43HRC	PL	JC8118 (JC8050)	~120	≤4.0	≤15.0	1,530	740	~120	≤4.0	≤15.0	1,530	920
			190	≤2.5	≤7.5	1,380	610	190	≤2.5	≤7.5	1,380	760
			235	≤1.5	≤3.8	1,220	490	235	≤1.5	≤3.8	1,220	610
Hardened die steel (SKD61, DAC, DHA) 42-52HRC	PL	JC8118 (DH102)	~120	≤3.5	≤12.5	1,270	610	~120	≤3.5	≤12.5	1,270	760
			190	≤2.5	≤6.2	1,140	490	190	≤2.5	≤6.2	1,140	620
			235	≤1.2	≤3.2	1,020	390	235	≤1.2	≤3.2	1,020	490
Hardened die steel (SKD11, SLD, DC11) 55-62HRC	PL	DH102	~120	≤2.5	≤10.0	890	360	~120	≤2.5	≤10.0	890	440
			190	≤1.5	≤5.0	800	290	190	≤1.5	≤5.0	800	360
			235	-	-	-	-	235	-	-	-	-
Grey & Nodular Cast iron (FC, FCD) below 300HB	PL	JC8118 (DH102)	~120	≤5.0	≤25.0	1,910	1,530	~120	≤5.0	≤25.0	1,910	1,910
			190	≤4.0	≤12.5	1,720	1,240	190	≤4.0	≤12.5	1,720	1,550
			235	≤3.0	≤6.2	1,530	980	235	≤3.0	≤6.2	1,530	1,220
Stainless steel (SUS304) below 250HB	PL (SL)	JC8050 (JC8118) (JC7518)	~120	≤5.0	≤20.0	1,910	1,150	~120	≤5.0	≤20.0	1,910	1,430
			190	≤3.0	≤10.0	1,720	930	190	≤3.0	≤10.0	1,720	1,160
			235	≤2.0	≤5.0	1,530	730	235	≤2.0	≤5.0	1,530	920
Titanium alloy (Ti-6Al-4V)	SL	DS118 (JC7518)	~120	≤5.0	≤15.0	760	460	~120	≤5.0	≤15.0	760	570
			190	≤3.0	≤7.5	680	370	190	≤3.0	≤7.5	680	460
			235	≤2.0	≤3.8	610	290	235	≤2.0	≤3.8	610	370
Heat resistant alloy (INCO718)	SL	DS118 (JC7518)	~120	≤5.0	≤15.0	380	230	~120	≤5.0	≤15.0	380	280
			190	≤3.0	≤7.5	340	180	190	≤3.0	≤7.5	340	230
			235	≤2.0	≤3.8	300	140	235	≤2.0	≤3.8	300	180
Aluminium alloy below 50-110HB	NL	FC18	~120	≤5.0	≤50.0	7,640	6,110	~120	≤5.0	≤50.0	7,640	7,640
			190	≤4.0	≤25.0	5,730	4,120	190	≤4.0	≤25.0	5,730	5,160
			235	≤3.0	≤12.5	3,820	2,440	235	≤3.0	≤12.5	3,820	3,060

Note

1. Please adjust cutting conditions according to machine rigidity or work rigidity.
2. In case of chatter occurring, recommended to reduce ap or rpm and keep feed per tooth.
3. ap should be reduced when using on low rigidity machine.
4. Use air blow.
5. Please scan QR code below for cutting conditions when using ZPMT-PL/NL/SL for side & bottom finishing.



QM MAX**MQX/QXP Type**

■ Recommended cutting conditions

● MQX Type (ZPMT-PL /NL/ SL insert)

3

Material	Chipbreaker	Grade	Tool dia.(mm)									
			30 / 32 / 35					32 / 35				
			5N					6N				
			r (mm)	a _p (mm)	a _p ×a _e (mm ²)	n (min ⁻¹)	V _f (mm/min)	r (mm)	a _p (mm)	a _p ×a _e (mm ²)	n (min ⁻¹)	V _f (mm/min)
Carbon steel (S50C, S55C) below 250HB	PL	JC8050 (JC8118) (CX75)	~160	≤5.0	≤24.0	1,590	1,190	~160	≤5.0	≤24.0	1,590	1,430
			240	≤3.0	≤12.0	1,430	960	240	≤3.0	≤12.0	1,430	1,160
			290	≤2.0	≤6.0	1,270	760	290	≤2.0	≤6.0	1,270	910
Tool & die steel (SKD61, SKD11) below 255HB	PL	JC8050 (JC8118)	~160	≤5.0	≤24.0	1,490	1,120	~160	≤5.0	≤24.0	1,490	1,340
			240	≤3.0	≤12.0	1,340	900	240	≤3.0	≤12.0	1,340	1,080
			290	≤2.0	≤6.0	1,190	710	290	≤2.0	≤6.0	1,190	860
Mold steel (HPM7, PX5, P20) 30-36 HRC	PL	JC8118 (JC8050)	~160	≤5.0	≤24.0	1,490	1,120	~160	≤5.0	≤24.0	1,490	1,340
			240	≤3.0	≤12.0	1,340	900	240	≤3.0	≤12.0	1,340	1,080
			290	≤2.0	≤6.0	1,190	710	290	≤2.0	≤6.0	1,190	860
Mold steel (NAK80, HPM1, P21) 38-43HRC	PL	JC8118 (JC8050)	~160	≤4.0	≤18.0	1,200	720	~160	≤4.0	≤18.0	1,200	860
			240	≤2.5	≤9.0	1,080	600	240	≤2.5	≤9.0	1,080	710
			290	≤2.0	≤4.5	960	480	290	≤2.0	≤4.5	960	580
Hardened die steel (SKD61, DAC, DHA) 42-52HRC	PL	JC8118 (DH102)	~160	≤3.5	≤15.0	1,000	600	~160	≤3.5	≤15.0	1,000	720
			240	≤2.5	≤7.5	900	490	240	≤2.5	≤7.5	900	580
			290	≤1.2	≤3.8	800	380	290	≤2.0	≤3.8	800	460
Hardened die steel (SKD11, SLD, DC11) 55-62HRC	PL	DH102	~160	≤2.5	≤12.0	700	350	~160	≤2.5	≤12.0	700	420
			240	≤1.5	≤6.0	630	280	240	≤1.5	≤6.0	630	340
			290	-	-	-	-	290	-	-	-	-
Grey & Nodular Cast iron (FC, FCD) below 300HB	PL	JC8118 (DH102)	~160	≤5.0	≤30.0	1,490	1,490	~160	≤5.0	≤30.0	1,490	1,790
			240	≤4.0	≤15.0	1,340	1,210	240	≤4.0	≤15.0	1,340	1,450
			290	≤3.0	≤7.5	1,190	950	290	≤3.0	≤7.5	1,190	1,140
Stainless steel (SUS304) below 250HB	PL (SL)	JC8050 (JC8118) (JC7518)	~160	≤5.0	≤24.0	1,490	1,120	~160	≤5.0	≤24.0	1,490	1,340
			240	≤3.0	≤12.0	1,340	900	240	≤3.0	≤12.0	1,340	1,080
			290	≤2.0	≤6.0	1,190	710	290	≤2.0	≤6.0	1,190	860
Titanium alloy (Ti-6Al-4V)	SL	DS118 (JC7518)	~160	≤5.0	≤18.0	600	450	~160	≤5.0	≤18.0	600	540
			240	≤3.0	≤9.0	540	360	240	≤3.0	≤9.0	540	440
			290	≤2.0	≤4.5	480	290	290	≤2.0	≤4.5	480	340
Heat resistant alloy (INCO718)	SL	DS118 (JC7518)	~160	≤5.0	≤18.0	300	230	~160	≤5.0	≤18.0	300	270
			240	≤3.0	≤9.0	270	180	240	≤3.0	≤9.0	270	220
			290	≤2.0	≤4.5	240	140	290	≤2.0	≤4.5	240	170
Aluminium alloy below 50-110HB	NL	FC18	~160	≤5.0	≤64.0	5,970	5,970	~160	≤5.0	≤64.0	5,970	7,160
			240	≤4.0	≤32.0	4,480	4,030	240	≤4.0	≤32.0	4,480	4,840
			290	≤3.0	≤16.0	2,990	2,390	290	≤3.0	≤16.0	2,990	2,870

Note

1. Please adjust cutting conditions according to machine rigidity or work rigidity.
2. In case of chatter occurring, recommended to reduce a_p or rpm and keep feed per tooth.
3. a_p should be reduced when using on low rigidity machine.
4. Use air blow.
5. Please scan QR code below for cutting conditions when using ZPMT-PL/NL/SL for side & bottom finishing.



QM MAX **MQX/QXP Type**

- Recommended cutting conditions
- MQX Type (ZPMT-PL /NL/ SL insert)

3

Material	Chipbreaker	Grade	Tool dia.(mm)									
			40 / 42					40				
			6N					7N				
			r (mm)	ap (mm)	ap×ae (mm ²)	n (min ⁻¹)	Vf (mm/min)	r (mm)	ap (mm)	ap×ae (mm ²)	n (min ⁻¹)	Vf (mm/min)
Carbon steel (S50C, S55C) below 250HB	PL	JC8050 (JC8118) (CX75)	~160	≤5.0	≤32.0	1,270	1,140	~160	≤5.0	≤32.0	1,270	1,330
			240	≤3.0	≤16.0	1,140	920	240	≤3.0	≤16.0	1,140	1,080
			290	≤2.0	≤8.0	1,020	730	290	≤2.0	≤8.0	1,020	860
Tool & die steel (SKD61, SKD11) below 255HB	PL	JC8050 (JC8118)	~160	≤5.0	≤32.0	1,190	1,070	~160	≤5.0	≤32.0	1,190	1,250
			240	≤3.0	≤16.0	1,070	870	240	≤3.0	≤16.0	1,070	1,010
			290	≤2.0	≤8.0	950	680	290	≤2.0	≤8.0	950	800
Mold steel (HPM7, PX5, P20) 30-36 HRC	PL	JC8118 (JC8050)	~160	≤5.0	≤32.0	1,190	1,070	~160	≤5.0	≤32.0	1,190	1,250
			240	≤3.0	≤16.0	1,070	870	240	≤3.0	≤16.0	1,070	1,010
			290	≤2.0	≤8.0	950	680	290	≤2.0	≤8.0	950	800
Mold steel (NAK80, HPM1, P21) 38-43HRC	PL	JC8118 (JC8050)	~160	≤4.0	≤24.0	950	680	~160	≤4.0	≤24.0	950	800
			240	≤2.5	≤12.0	860	570	240	≤2.5	≤12.0	860	660
			290	≤2.0	≤6.0	760	460	290	≤2.0	≤6.0	760	530
Hardened die steel (SKD61, DAC, DHA) 42-52HRC	PL	JC8118 (DH102)	~160	≤3.5	≤20.0	800	580	~160	≤3.5	≤20.0	800	670
			240	≤2.5	≤10.0	720	470	240	≤2.5	≤10.0	720	540
			290	≤1.2	≤5.0	640	370	290	≤1.2	≤5.0	640	430
Hardened die steel (SKD11, SLD, DC11) 55-62HRC	PL	DH102	~160	≤2.5	≤16.0	560	340	~160	≤2.5	≤16.0	560	390
			240	≤1.5	≤8.0	500	270	240	≤1.5	≤8.0	500	310
			290	-	-	-	-	290	-	-	-	-
Grey & Nodular cast iron (FC, FCD) below 300HB	PL	JC8118 (DH102)	~160	≤5.0	≤40.0	1,190	1,430	~160	≤5.0	≤40.0	1,190	1,670
			240	≤4.0	≤20.0	1,070	1,160	240	≤4.0	≤20.0	1,070	1,350
			290	≤3.0	≤10.0	950	910	290	≤3.0	≤10.0	950	1,060
Stainless steel (SUS304) below 250HB	PL (SL)	JC8050 (JC8118) (JC7518)	~160	≤5.0	≤32.0	1,190	1,070	~160	≤5.0	≤32.0	1,190	1,250
			240	≤3.0	≤16.0	1,070	870	240	≤3.0	≤16.0	1,070	1,010
			290	≤2.0	≤8.0	950	680	290	≤2.0	≤8.0	950	800
Titanium alloy (Ti-6Al-4V)	SL	DS118 (JC7518)	~160	≤5.0	≤24.0	480	430	~160	≤5.0	≤24.0	480	500
			240	≤3.0	≤12.0	430	350	240	≤3.0	≤12.0	430	410
			290	≤2.0	≤6.0	380	270	290	≤2.0	≤6.0	380	320
Heat resistant alloy (INCO718)	SL	DS118 (JC7518)	~160	≤5.0	≤24.0	240	220	~160	≤5.0	≤24.0	240	250
			240	≤3.0	≤12.0	220	180	240	≤3.0	≤12.0	220	210
			290	≤2.0	≤6.0	190	140	290	≤2.0	≤6.0	190	160
Aluminium alloy below 50-110HB	NL	FC18	~160	≤5.0	≤80.0	4,780	5,740	~160	≤5.0	≤80.0	4,780	6,690
			240	≤4.0	≤40.0	3,580	3,870	240	≤4.0	≤40.0	3,580	4,510
			290	≤3.0	≤20.0	2,390	2,290	290	≤3.0	≤20.0	2,390	2,680

Note

1. Please adjust cutting conditions according to machine rigidity or work rigidity.
2. In case of chatter occurring, recommended to reduce ap or rpm and keep feed per tooth.
3. ap should be reduced when using on low rigidity machine.
4. Use air blow.
5. Please scan QR code below for cutting conditions when using ZPMT-PL/NL/SL for side & bottom finishing.



QM MAX**MQX/QXP Type**

- Recommended cutting conditions
● QXP Type (ZPMT-PL /NL/ SL insert)

3

Material	Chipbreaker	Grade	Tool dia.(mm)									
			40									
			6N					7N				
			r (mm)	a _p (mm)	a _p ×a _e (mm ²)	n (min ⁻¹)	V _f (mm/min)	r (mm)	a _p (mm)	a _p ×a _e (mm ²)	n (min ⁻¹)	V _f (mm/min)
Carbon steel (S50C, S55C) below 250HB	PL	JC8050 (JC8118) (CX75)	~150	≤5.0	≤32.0	1,270	1,140	~150	≤5.0	≤32.0	1,270	1,330
			200	≤3.0	≤16.0	1,140	920	200	≤3.0	≤16.0	1,140	1,080
			250	≤2.0	≤8.0	1,020	730	250	≤2.0	≤8.0	1,020	860
Tool & die steel (SKD61, SKD11) below 255HB	PL	JC8050 (JC8118)	~150	≤5.0	≤32.0	1,190	1,070	~150	≤5.0	≤32.0	1,190	1,250
			200	≤3.0	≤16.0	1,070	870	200	≤3.0	≤16.0	1,070	1,010
			250	≤2.0	≤8.0	950	680	250	≤2.0	≤8.0	950	800
Mold steel (HPM7, PX5, P20) 30-36 HRC	PL	JC8118 (JC8050)	~150	≤5.0	≤32.0	1,190	1,070	~150	≤5.0	≤32.0	1,190	1,250
			200	≤3.0	≤16.0	1,070	870	200	≤3.0	≤16.0	1,070	1,010
			250	≤2.0	≤8.0	950	680	250	≤2.0	≤8.0	950	800
Mold steel (NAK80, HPM1, P21) 38-43HRC	PL	JC8118 (JC8050)	~150	≤4.0	≤24.0	950	680	~150	≤4.0	≤24.0	950	800
			200	≤2.5	≤12.0	860	570	200	≤2.5	≤12.0	860	660
			250	≤2.0	≤6.0	760	460	250	≤2.0	≤6.0	760	530
Hardened die steel (SKD61, DAC, DHA) 42-52HRC	PL	JC8118 (DH102)	~150	≤3.5	≤20.0	800	580	~150	≤3.5	≤20.0	800	670
			200	≤2.5	≤10.0	720	470	200	≤2.5	≤10.0	720	540
			250	≤1.2	≤5.0	640	370	250	≤1.2	≤5.0	640	430
Hardened die steel (SKD11, SLD, DC11) 55-62HRC	PL	DH102	~150	≤2.5	≤16.0	560	340	~150	≤2.5	≤16.0	560	390
			200	≤1.5	≤8.0	500	270	200	≤1.5	≤8.0	500	310
			250	-	-	-	-	250	-	-	-	-
Grey & Nodular cast iron (FC, FCD) below 300HB	PL	JC8118 (DH102)	~150	≤5.0	≤40.0	1,190	1,430	~150	≤5.0	≤40.0	1,190	1,670
			200	≤4.0	≤20.0	1,070	1,160	200	≤4.0	≤20.0	1,070	1,350
			250	≤3.0	≤10.0	950	910	250	≤3.0	≤10.0	950	1,060
Stainless steel (SUS304) below 250HB	PL (SL)	JC8050 (JC8118) (JC7518)	~150	≤5.0	≤32.0	1,190	1,070	~150	≤5.0	≤32.0	1,190	1,250
			200	≤3.0	≤16.0	1,070	870	200	≤3.0	≤16.0	1,070	1,010
			250	≤2.0	≤8.0	950	680	250	≤2.0	≤8.0	950	800
Titanium alloy (Ti-6Al-4V)	SL	DS118 (JC7518)	~150	≤5.0	≤24.0	480	430	~150	≤5.0	≤24.0	480	500
			200	≤3.0	≤12.0	430	350	200	≤3.0	≤12.0	430	410
			250	≤2.0	≤6.0	380	270	250	≤2.0	≤6.0	380	320
Heat resistant alloy (INCO718)	SL	DS118 (JC7518)	~150	≤5.0	≤24.0	240	220	~150	≤5.0	≤24.0	240	250
			200	≤3.0	≤12.0	220	180	200	≤3.0	≤12.0	220	210
			250	≤2.0	≤6.0	190	140	250	≤2.0	≤6.0	190	160
Aluminium alloy below 50-110HB	NL	FC18	~150	≤5.0	≤80.0	4,780	5,740	~150	≤5.0	≤80.0	4,780	6,690
			200	≤4.0	≤40.0	3,580	3,870	200	≤4.0	≤40.0	3,580	4,510
			250	≤3.0	≤20.0	2,390	2,290	250	≤3.0	≤20.0	2,390	2,680

Note

1. Please adjust cutting conditions according to machine rigidity or work rigidity.
2. In case of chatter occurring, recommended to reduce a_p or rpm and keep feed per tooth.
3. a_p should be reduced when using on low rigidity machine.
4. Use air blow.
5. Please scan QR code below for cutting conditions when using ZPMT-PL/NL/SL for side & bottom finishing.



QM MAX **MQX/QXP Type**

- Recommended cutting conditions
- QXP Type (ZPMT-PL /NL/ SL insert)

3

Material	Chipbreaker	Grade	Tool dia.(mm)									
			50					50 / 52				
			7N					8N				
			r (mm)	ap (mm)	ap×ae (mm ²)	n (min ⁻¹)	Vf (mm/min)	r (mm)	ap (mm)	ap×ae (mm ²)	n (min ⁻¹)	Vf (mm/min)
Carbon steel (S50C, S55C) below 250HB	PL	JC8050 (JC8118) (CX75)	~200	≦5.0	≦40.0	1,020	1,070	~200	≦5.0	≦40.0	1,020	1,220
			250	≦3.0	≦20.0	920	870	250	≦3.0	≦20.0	920	990
			300	≦2.0	≦10.0	820	690	300	≦2.0	≦10.0	820	790
Tool & die steel (SKD61, SKD11) below 255HB	PL	JC8050 (JC8118)	~200	≦5.0	≦40.0	950	1,000	~200	≦5.0	≦40.0	950	1,140
			250	≦3.0	≦20.0	860	810	250	≦3.0	≦20.0	860	930
			300	≦2.0	≦10.0	760	640	300	≦2.0	≦10.0	760	730
Mold steel (HPM7, PX5, P20) 30-36 HRC	PL	JC8118 (JC8050)	~200	≦5.0	≦40.0	950	1,000	~200	≦5.0	≦40.0	950	1,140
			250	≦3.0	≦20.0	860	810	250	≦3.0	≦20.0	860	930
			300	≦2.0	≦10.0	760	640	300	≦2.0	≦10.0	760	730
Mold steel (NAK80, HPM1, P21) 38-43HRC	PL	JC8118 (JC8050)	~200	≦4.0	≦30.0	760	640	~200	≦4.0	≦30.0	760	730
			250	≦2.5	≦15.0	680	520	250	≦2.5	≦15.0	680	600
			300	≦2.0	≦7.5	610	430	300	≦2.0	≦7.5	610	490
Hardened die steel (SKD61, DAC, DHA) 42-52HRC	PL	JC8118 (DH102)	~200	≦3.5	≦25.0	640	540	~200	≦3.5	≦25.0	640	610
			250	≦2.0	≦12.5	580	440	250	≦2.0	≦12.5	580	500
			300	≦1.2	≦6.0	510	340	300	≦1.2	≦6.0	510	390
Hardened die steel (SKD11, SLD, DC11) 55-62HRC	PL	DH102	~200	≦2.5	≦20.0	450	320	~200	≦2.5	≦20.0	450	360
			250	≦1.5	≦10.0	400	250	250	≦1.5	≦10.0	400	290
			300	≦1.0	≦5.0	360	200	300	≦1.0	≦5.0	360	230
Gery & Nodular cast iron (FC, FCD) below 300HB	PL	JC8118 (DH102)	~200	≦5.0	≦50.0	950	1,330	~200	≦5.0	≦50.0	950	1,520
			250	≦4.0	≦25.0	860	1,080	250	≦4.0	≦25.0	860	1,240
			300	≦3.0	≦12.5	760	850	300	≦3.0	≦12.5	760	970
Stainless steel (SUS304) below 250HB	PL (SL)	JC8050 (JC8118) (JC7518)	~200	≦5.0	≦40.0	950	1,000	~200	≦5.0	≦40.0	950	1,140
			250	≦3.0	≦20.0	860	810	250	≦3.0	≦20.0	860	930
			300	≦2.0	≦10.0	760	640	300	≦2.0	≦10.0	760	730
Titanium alloy (Ti-6Al-4V)	SL	DS118 (JC7518)	~200	≦5.0	≦30.0	380	400	~200	≦5.0	≦30.0	380	460
			250	≦3.0	≦15.0	340	320	250	≦3.0	≦15.0	340	370
			300	≦2.0	≦7.5	300	250	300	≦2.0	≦7.5	300	290
Heat resistant alloy (INCO718)	SL	DS118 (JC7518)	~200	≦5.0	≦30.0	190	200	~200	≦5.0	≦30.0	190	230
			250	≦3.0	≦15.0	170	160	250	≦3.0	≦15.0	170	180
			300	≦2.0	≦7.5	150	130	300	≦2.0	≦7.5	150	140
Aluminium alloy below 50-110HB	NL	FC18	~200	≦5.0	≦100.0	3,820	5,350	~200	≦5.0	≦100.0	3,820	6,110
			250	≦4.0	≦50.0	2,860	3,600	250	≦4.0	≦50.0	2,860	4,120
			300	≦3.0	≦25.0	1,910	2,140	300	≦3.0	≦25.0	1,910	2,440

Note

1. Please adjust cutting conditions according to machine rigidity or work rigidity.
2. In case of chatter occurring, recommended to reduce ap or rpm and keep feed per tooth.
3. ap should be reduced when using on low rigidity machine.
4. Use air blow.
5. Please scan QR code below for cutting conditions when using ZPMT-PL/NL/SL for side & bottom finishing.



QM MAX**MQX/QXP Type**

- Recommended cutting conditions
- QXP Type (ZPMT-PL /NL/ SL insert)

3

Material	Chipbreaker	Grade	Tool dia.(mm)						
			63/66						
			8N						
			r (mm)	ap (mm)	ap×ae (mm ²)	n (min ⁻¹)	Vf (mm/min)		
Carbon steel (S50C, S55C) below 250HB	PL	JC8050 (JC8118) (CX75)	~250	≤5.0	≤50.0	810	970		
			300	≤3.0	≤25.0	730	790		
			350	≤2.0	≤12.5	650	620		
Tool & die steel (SKD61, SKD11) below 255HB	PL	JC8050 (JC8118)	~250	≤5.0	≤50.0	760	910		
			300	≤3.0	≤25.0	680	730		
			350	≤2.0	≤12.5	610	580		
Mold steel (HPM7, PX5, P20) 30-36 HRC	PL	JC8118 (JC8050)	~250	≤5.0	≤50.0	760	910		
			300	≤3.0	≤25.0	680	730		
			350	≤2.0	≤12.5	610	580		
Mold steel (NAK80, HPM1, P21) 38-43HRC	PL	JC8118 (JC8050)	~250	≤4.0	≤38.0	610	590		
			300	≤2.5	≤19.0	550	480		
			350	≤2.0	≤9.5	490	390		
Hardened die steel (SKD61, DAC, DHA) 42-52HRC	PL	JC8118 (DH102)	~250	≤3.5	≤32.0	500	480		
			300	≤2.5	≤16.0	450	390		
			350	≤1.5	≤7.5	400	310		
Hardened die steel (SKD11, SLD, DC11) 55-62HRC	PL	DH102	~250	≤2.5	≤25.0	350	280		
			300	≤1.5	≤12.5	320	230		
			350	≤1.0	≤6.5	280	180		
Grey & Nodular cast iron (FC, FCD) below 300HB	PL	JC8118 (DH102)	~250	≤5.0	≤64.0	760	1,220		
			300	≤4.0	≤32.0	680	980		
			350	≤3.0	≤16.0	610	780		
Stainless steel (SUS304) below 250HB	PL (SL)	JC8050 (JC8118) (JC7518)	~250	≤5.0	≤50.0	760	910		
			300	≤3.0	≤25.0	680	730		
			350	≤2.0	≤12.5	610	580		
Titanium alloy (Ti-6Al-4V)	SL	DS118 (JC7518)	~250	≤5.0	≤38.0	300	360		
			300	≤3.0	≤19.0	270	290		
			350	≤2.0	≤9.5	240	230		
Heat resistant alloy (INCO718)	SL	DS118 (JC7518)	~250	≤5.0	≤38.0	150	180		
			300	≤3.0	≤19.0	140	150		
			350	≤2.0	≤9.5	120	110		
Aluminium alloy below 50-110HB	NL	FC18	~250	≤5.0	≤128.0	3,030	4,850		
			300	≤4.0	≤63.0	2,270	3,270		
			350	≤3.0	≤31.5	1,520	1,940		

Note

1. Please adjust cutting conditions according to machine rigidity or work rigidity.
2. In case of chatter occurring, recommended to reduce ap or rpm and keep feed per tooth.
3. ap should be reduced when using on low rigidity machine.
4. Use air blow.
5. Please scan QR code below for cutting conditions when using ZPMT-PL/NL/SL for side & bottom finishing.



QM MAX**MQX/QXP Type**

■ Recommended cutting conditions

● MQX Type (YPHW-15 /-F insert) - Vertical side finishing (UP&DOWN milling)

4

Material	Grade	Tool dia.(mm)														
		16/17					20					20/21				
		2N					3N					4N				
		ℓ (mm)	Pr (mm)	ae (mm)	n (min ⁻¹)	Vf (mm/min)	ℓ (mm)	Pr (mm)	ae (mm)	n (min ⁻¹)	Vf (mm/min)	ℓ (mm)	Pr (mm)	ae (mm)	n (min ⁻¹)	Vf (mm/min)
Carbon steel (S50C, S55C) below 250HB	JC8015 (DH102)	~70	0.5	<0.2	8,950	2,680	~70	0.6	<0.2	7,160	3,220	~70	0.6	<0.2	7,160	4,290
		120	0.5	<0.2	6,960	1,390	120	0.6	<0.2	7,160	2,790	120	0.6	<0.2	7,160	3,720
		160	0.5	<0.2	6,960	1,110	190	0.6	<0.2	5,570	1,670	190	0.6	<0.2	5,570	2,230
Tool & die steel (SKD61, SKD11) below 255HB	JC8015 (DH102)	~70	0.5	<0.2	7,960	2,390	~70	0.6	<0.2	6,370	3,220	~70	0.6	<0.2	6,370	4,290
		120	0.5	<0.2	5,970	1,190	120	0.6	<0.2	6,370	2,480	120	0.6	<0.2	6,370	3,310
		160	0.5	<0.2	5,970	960	190	0.6	<0.2	4,770	1,430	190	0.6	<0.2	4,770	1,910
Mold steel (HPM7, PX5, P20) 30-36 HRC	JC8015 (DH102)	~70	0.5	<0.2	6,960	1,670	~70	0.6	<0.2	5,570	2,000	~70	0.6	<0.2	5,570	2,670
		120	0.5	<0.2	4,970	840	120	0.6	<0.2	5,570	1,670	120	0.6	<0.2	5,570	2,230
		160	0.5	<0.2	4,970	700	190	0.6	<0.2	3,980	960	190	0.6	<0.2	3,980	1,280
Mold steel (NAK80, HPM1, P21) 38-43HRC	JC8015 (DH102)	~70	0.5	<0.2	4,980	1,200	~70	0.6	<0.2	3,980	1,430	~70	0.6	<0.2	3,980	1,910
		120	0.5	<0.2	3,560	600	120	0.6	<0.2	3,980	1,190	120	0.6	<0.2	3,980	1,590
		160	0.5	<0.2	3,560	500	190	0.6	<0.2	2,840	690	190	0.6	<0.2	2,840	920
Hardened die steel (SKD61, DAC, DHA) 42-52HRC	DH102 (JC8015)	~70	0.5	<0.15	3,380	680	~70	0.6	<0.15	2,710	810	~70	0.6	<0.15	2,710	1,080
		120	0.5	<0.15	2,400	340	120	0.6	<0.15	2,710	670	120	0.6	<0.15	2,710	890
		160	0.5	<0.15	2,400	280	190	0.6	<0.15	1,940	390	190	0.6	<0.15	1,940	520
Grey & Nodular cast iron (FC, FCD) below 300HB	JC8015 (DH102)	~70	0.5	<0.2	10,900	3,270	~70	0.6	<0.2	8,750	3,940	~70	0.6	<0.2	8,750	5,250
		120	0.5	<0.2	8,950	2,150	120	0.6	<0.2	7,160	2,580	120	0.6	<0.2	7,160	3,440
		160	0.5	<0.2	8,950	1,790	190	0.6	<0.2	7,160	2,150	190	0.6	<0.2	7,160	2,870

Note

1. Please adjust cutting conditions according to machine rigidity or work rigidity.
2. In case of chatter occurring, recommended to reduce ap or rpm and keep feed per tooth.
3. ap should be reduced when using on low rigidity machine.
4. Use air blow.

QM MAX**MQX/QXP Type**

■ Recommended cutting conditions

● MQX Type (YPHW-15 /-F insert) - Vertical side finishing (UP&DOWN milling)

4

Material	Grade	Tool dia.(mm)														
		25/26					25/26/28					30/32/35				
		4N					5N					5N				
		ℓ (mm)	Pf (mm)	ae (mm)	n (min ⁻¹)	Vf (mm/min)	ℓ (mm)	Pf (mm)	ae (mm)	n (min ⁻¹)	Vf (mm/min)	ℓ (mm)	Pf (mm)	ae (mm)	n (min ⁻¹)	Vf (mm/min)
Carbon steel (S50C, S55C) below 250HB	JC8015 (DH102)	~90	0.7	<0.2	5,730	4,120	~90	0.7	<0.2	5,730	6,210	~100	0.8	<0.2	4,480	4,030
		140	0.7	<0.2	5,730	3,440	140	0.7	<0.2	5,730	4,300	150	0.8	<0.2	4,480	4,030
		210	0.7	<0.2	4,460	2,140	210	0.7	<0.2	4,460	2,680	210	0.8	<0.2	3,480	2,610
Tool & die steel (SKD61, SKD11) below 255HB	JC8015 (DH102)	~90	0.7	<0.2	5,090	3,660	~90	0.7	<0.2	5,090	4,580	~100	0.8	<0.2	3,980	3,580
		140	0.7	<0.2	5,090	3,050	140	0.7	<0.2	5,090	3,810	150	0.8	<0.2	3,980	3,580
		210	0.7	<0.2	3,820	1,830	210	0.7	<0.2	3,820	2,290	210	0.8	<0.2	2,980	1,740
Mold steel (HPM7, PX5, P20) 30-36 HRC	JC8015 (DH102)	~90	0.7	<0.2	4,460	2,680	~90	0.7	<0.2	4,460	3,350	~100	0.8	<0.2	3,480	2,610
		140	0.7	<0.2	4,460	2,140	140	0.7	<0.2	4,460	2,680	150	0.8	<0.2	3,480	2,610
		210	0.7	<0.2	3,180	1,270	210	0.7	<0.2	3,180	1,590	210	0.8	<0.2	2,490	1,250
Mold steel (NAK80, HPM1, P21) 38-43HRC	JC8015 (DH102)	~90	0.7	<0.2	3,180	1,530	~90	0.7	<0.2	3,180	1,910	~100	0.8	<0.2	2,490	1,500
		140	0.7	<0.2	3,180	1,220	140	0.7	<0.2	3,180	1,520	150	0.8	<0.2	2,490	1,500
		210	0.7	<0.2	2,270	730	210	0.7	<0.2	2,270	910	210	0.8	<0.2	1,780	720
Hardened die steel (SKD61, DAC, DHA) 42-52HRC	DH102 (JC8015)	~90	0.7	<0.15	2,160	860	~90	0.7	<0.15	2,160	1,080	~100	0.8	<0.15	1,690	850
		140	0.7	<0.15	2,160	690	140	0.7	<0.15	2,160	860	150	0.8	<0.15	1,690	850
		210	0.7	<0.15	1,540	410	210	0.7	<0.15	1,540	510	210	0.8	<0.15	1,210	410
Grey & Nodular cast iron (FC, FCD) below 300HB	JC8015 (DH102)	~90	0.7	<0.2	7,000	4,200	~90	0.7	<0.2	7,000	5,250	~100	0.8	<0.2	5,470	4,100
		140	0.7	<0.2	5,730	2,750	140	0.7	<0.2	5,730	3,440	150	0.8	<0.2	5,470	4,100
		210	0.7	<0.2	5,730	2,290	210	0.7	<0.2	5,730	2,860	210	0.8	<0.2	4,480	2,240

Note

1. Please adjust cutting conditions according to machine rigidity or work rigidity.
2. In case of chatter occurring, recommended to reduce ap or rpm and keep feed per tooth.
3. ap should be reduced when using on low rigidity machine.
4. Use air blow.

QM MAX**MQX/QXP Type**

■ Recommended cutting conditions

● MQX Type (YPHW-15 /-F insert) - Vertical side finishing (UP&DOWN milling)

4

Material	Grade	Tool dia.(mm)														
		32/35					40/42					40				
		6N					6N					7N				
		ℓ (mm)	Pf (mm)	ae (mm)	n (min ⁻¹)	Vf (mm/min)	ℓ (mm)	Pf (mm)	ae (mm)	n (min ⁻¹)	Vf (mm/min)	ℓ (mm)	Pf (mm)	ae (mm)	n (min ⁻¹)	Vf (mm/min)
Carbon steel (S50C, S55C) below 250HB	JC8015 (DH102)	~100	0.8	<0.2	4,480	4,830	~100	0.88	<0.2	3,580	3,870	~100	0.88	<0.2	3,580	4,520
		150	0.8	<0.2	4,480	4,830	150	0.88	<0.2	3,580	3,870	150	0.88	<0.2	3,580	4,520
		210	0.8	<0.2	3,480	3,130	210	0.88	<0.2	2,790	2,010	210	0.88	<0.2	2,790	2,350
Tool & die steel (SKD61, SKD11) below 255HB	JC8015 (DH102)	~100	0.8	<0.2	3,980	4,300	~100	0.88	<0.2	3,180	3,430	~100	0.88	<0.2	3,180	4,000
		150	0.8	<0.2	3,980	4,300	150	0.88	<0.2	3,180	3,430	150	0.88	<0.2	3,180	4,000
		210	0.8	<0.2	2,980	2,090	210	0.88	<0.2	2,390	1,720	210	0.88	<0.2	2,390	2,010
Mold steel (HPM7, PX5, P20) 30-36 HRC	JC8015 (DH102)	~100	0.8	<0.2	3,480	3,130	~100	0.88	<0.2	2,790	2,510	~100	0.88	<0.2	2,790	2,930
		150	0.8	<0.2	3,480	3,130	150	0.88	<0.2	2,790	2,510	150	0.88	<0.2	2,790	2,930
		210	0.8	<0.2	2,490	1,500	210	0.88	<0.2	1,990	1,430	210	0.88	<0.2	1,990	1,670
Mold steel (NAK80, HPM1, P21) 38-43HRC	JC8015 (DH102)	~100	0.8	<0.2	2,490	1,800	~100	0.88	<0.2	1,990	1,430	~100	0.88	<0.2	1,990	1,670
		150	0.8	<0.2	2,490	1,800	150	0.88	<0.2	1,990	1,430	150	0.88	<0.2	1,990	1,670
		210	0.8	<0.2	1,780	860	210	0.88	<0.2	1,420	820	210	0.88	<0.2	1,420	960
Hardened die steel (SKD61, DAC, DHA) 42-52HRC	DH102 (JC8015)	~100	0.8	<0.15	1,690	1,020	~100	0.88	<0.15	1,350	810	~100	0.88	<0.15	1,350	950
		150	0.8	<0.15	1,690	1,020	150	0.88	<0.15	1,350	810	150	0.88	<0.15	1,350	950
		210	0.8	<0.15	1,210	490	210	0.88	<0.15	960	460	210	0.88	<0.15	960	540
Grey & Nodular cast iron (FC, FCD) below 300HB	JC8015 (DH102)	~100	0.8	<0.2	5,470	4,920	~100	0.88	<0.2	4,380	3,940	~100	0.88	<0.2	4,380	4,600
		150	0.8	<0.2	5,470	4,920	150	0.88	<0.2	4,380	3,940	150	0.88	<0.2	4,380	4,600
		210	0.8	<0.2	4,480	2,690	210	0.88	<0.2	3,580	2,580	210	0.88	<0.2	3,580	3,010

Note

1. Please adjust cutting conditions according to machine rigidity or work rigidity.
2. In case of chatter occurring, recommended to reduce ap or rpm and keep feed per tooth.
3. ap should be reduced when using on low rigidity machine.
4. Use air blow.

QM MAX**MQX/QXP Type**

■ Recommended cutting conditions

● QXP Type (YPHW-15 /-F insert) - Vertical side finishing (UP&DOWN milling)

4

Material	Grade	Tool dia.(mm)									
		40									
		6N					7N				
ℓ (mm)	P_f (mm)	a_e (mm)	n (min ⁻¹)	V_f (mm/min)	ℓ (mm)	P_f (mm)	a_e (mm)	n (min ⁻¹)	V_f (mm/min)		
Carbon steel (S50C, S55C) below 250HB	JC8015 (DH102)	~150	0.88	<0.2	3,580	3,870	~150	0.88	<0.2	3,580	4,520
		200	0.88	<0.2	3,580	3,870	200	0.88	<0.2	3,580	4,520
		250	0.88	<0.2	3,580	3,220	250	0.88	<0.2	3,580	3,760
		300	0.88	<0.2	2,790	2,010	300	0.88	<0.2	2,790	2,350
		350	-	-	-	-	350	-	-	-	-
Tool & die steel (SKD61, SKD11) below 255HB	JC8015 (DH102)	~150	0.88	<0.2	3,180	3,430	~150	0.88	<0.2	3,180	4,000
		200	0.88	<0.2	3,180	3,430	200	0.88	<0.2	3,180	4,000
		250	0.88	<0.2	3,180	2,860	250	0.88	<0.2	3,180	3,340
		300	0.88	<0.2	2,390	1,720	300	0.88	<0.2	2,390	2,010
		350	-	-	-	-	350	-	-	-	-
Mold steel (HPM7, PX5, P20) 30-36 HRC	JC8015 (DH102)	~150	0.88	<0.2	2,790	2,510	~150	0.88	<0.2	2,790	2,930
		200	0.88	<0.2	2,790	2,510	200	0.88	<0.2	2,790	2,930
		250	0.88	<0.2	2,790	2,010	250	0.88	<0.2	2,790	2,350
		300	0.88	<0.2	1,990	1,190	300	0.88	<0.2	1,990	1,390
		350	-	-	-	-	350	-	-	-	-
Mold steel (NAK80, HPM1, P21) 38-43HRC	JC8015 (DH102)	~150	0.88	<0.2	1,990	1,430	~150	0.88	<0.2	1,990	1,670
		200	0.88	<0.2	1,990	1,430	200	0.88	<0.2	1,990	1,670
		250	0.88	<0.2	1,990	1,150	250	0.88	<0.2	1,990	1,340
		300	0.88	<0.2	1,420	680	300	0.88	<0.2	1,420	790
		350	-	-	-	-	350	-	-	-	-
Hardened die steel (SKD61, DAC, DHA) 42-52HRC	DH102 (JC8015)	~150	0.88	<0.15	1,350	810	~150	0.88	<0.15	1,350	950
		200	0.88	<0.15	1,350	810	200	0.88	<0.15	1,350	950
		250	0.88	<0.15	1,350	650	250	0.88	<0.15	1,350	760
		300	0.88	<0.15	960	390	300	0.88	<0.15	960	460
		350	-	-	-	-	350	-	-	-	-
Grey & Nodular cast iron (FC, FCD) below 300HB	JC8015 (DH102)	~150	0.88	<0.2	4,380	3,940	~150	0.88	<0.2	4,380	4,600
		200	0.88	<0.2	4,380	3,940	200	0.88	<0.2	4,380	4,600
		250	0.88	<0.2	3,580	2,580	250	0.88	<0.2	3,580	3,010
		300	0.88	<0.2	3,580	2,150	300	0.88	<0.2	3,580	2,510
		350	-	-	-	-	350	-	-	-	-

Note

1. Please adjust cutting conditions according to machine rigidity or work rigidity.
2. In case of chatter occurring, recommended to reduce a_p or rpm and keep feed per tooth.
3. a_p should be reduced when using on low rigidity machine.
4. Use air blow.

QM MAX**MQX/QXP Type**

■ Recommended cutting conditions

● QXP Type (YPHW-15 /-F insert) - Vertical side finishing (UP & DOWN milling)

4

Material	Grade	Tool dia.(mm)									
		50					50/52				
		7N					8N				
ℓ (mm)	Pf (mm)	a _e (mm)	n (min ⁻¹)	V _f (mm/min)	ℓ (mm)	Pf (mm)	a _e (mm)	n (min ⁻¹)	V _f (mm/min)		
Carbon steel (S50C, S55C) below 255HB	JC8015 (DH102)	~150	1	<0.2	2,860	3,600	~150	1	<0.2	2,860	4,110
		200	1	<0.2	2,860	3,600	200	1	<0.2	2,860	4,110
		250	1	<0.2	2,860	3,600	250	1	<0.2	2,860	4,110
		300	1	<0.2	2,860	3,000	300	1	<0.2	2,860	3,430
		350	1	<0.2	2,860	3,000	350	1	<0.2	2,860	3,430
Tool & die steel (SKD61, SKD11) below 255HB	JC8015 (DH102)	~150	1	<0.2	2,550	3,210	~150	1	<0.2	2,550	3,670
		200	1	<0.2	2,550	3,210	200	1	<0.2	2,550	3,670
		250	1	<0.2	2,550	3,210	250	1	<0.2	2,550	3,670
		300	1	<0.2	2,550	2,680	300	1	<0.2	2,550	3,060
		350	1	<0.2	2,550	2,680	350	1	<0.2	2,550	3,060
Mold steel (HPM7, PX5, P20) 30-36 HRC	JC8015 (DH102)	~150	1	<0.2	2,230	2,340	~150	1	<0.2	2,230	2,670
		200	1	<0.2	2,230	2,340	200	1	<0.2	2,230	2,670
		250	1	<0.2	2,230	2,340	250	1	<0.2	2,230	2,670
		300	1	<0.2	2,230	1,870	300	1	<0.2	2,230	2,140
		350	1	<0.2	2,230	1,870	350	1	<0.2	2,230	2,140
Mold steel (NAK80, HPM1, P21) 38-43HRC	JC8015 (DH102)	~150	1	<0.2	1,590	1,340	~150	1	<0.2	1,590	1,530
		200	1	<0.2	1,590	1,340	200	1	<0.2	1,590	1,530
		250	1	<0.2	1,590	1,340	250	1	<0.2	1,590	1,530
		300	1	<0.2	1,590	1,070	300	1	<0.2	1,590	1,220
		350	1	<0.2	1,590	1,070	350	1	<0.2	1,590	1,220
Hardened die steel (SKD61, DAC, DHA) 42-52HRC	DH102 (JC8015)	~150	1	<0.15	1,080	760	~150	1	<0.15	1,080	870
		200	1	<0.15	1,080	760	200	1	<0.15	1,080	870
		250	1	<0.15	1,080	760	250	1	<0.15	1,080	870
		300	1	<0.15	1,080	610	300	1	<0.15	1,080	700
		350	1	<0.15	1,080	610	350	1	<0.15	1,080	700
Grey & Nodular cast iron (FC, FCD) below 300HB	JC8015 (DH102)	~150	1	<0.2	3,500	3,680	~150	1	<0.2	3,500	4,210
		200	1	<0.2	3,500	3,680	200	1	<0.2	3,500	4,210
		250	1	<0.2	3,500	3,680	250	1	<0.2	3,500	4,210
		300	1	<0.2	2,860	2,400	300	1	<0.2	2,860	2,740
		350	1	<0.2	2,860	2,400	350	1	<0.2	2,860	2,740

Note

1. Please adjust cutting conditions according to machine rigidity or work rigidity.
2. In case of chatter occurring, recommended to reduce ap or rpm and keep feed per tooth.
3. ap should be reduced when using on low rigidity machine.
4. Use air blow.

QM MAX**MQX/QXP Type**

■ Recommended cutting conditions

● QXP Type (YPHW-15 /-F insert) - Vertical side finishing (UP & DOWN milling)

4

Material	Grade	Tool dia.(mm)									
		63/66									
		8N									
φ (mm)	Pf (mm)	ae (mm)	n (min ⁻¹)	Vf (mm/min)							
Carbon steel (S50C, S55C) below 250HB	JC8015 (DH102)	~200	1.12	<0.2	2,270	3,260					
		250	1.12	<0.2	2,270	3,260					
		300	1.12	<0.2	2,270	3,260					
		350	1.12	<0.2	2,270	2,720					
		400	1.12	<0.2	2,270	2,720					
Tool & die steel (SKD61, SKD11) below 255HB	JC8015 (DH102)	~200	1.12	<0.2	2,020	2,910					
		250	1.12	<0.2	2,020	2,910					
		300	1.12	<0.2	2,020	2,910					
		350	1.12	<0.2	2,020	2,420					
		400	1.12	<0.2	2,020	2,420					
Mold steel (HPM7, PX5, P20) 30-36 HRC	JC8015 (DH102)	~200	1.12	<0.2	1,770	2,120					
		250	1.12	<0.2	1,770	2,120					
		300	1.12	<0.2	1,770	2,120					
		350	1.12	<0.2	1,770	1,700					
		400	1.12	<0.2	1,770	1,700					
Mold steel (NAK80, HPM1, P21) 38-43HRC	JC8015 (DH102)	~200	1.12	<0.2	1,260	1,210					
		250	1.12	<0.2	1,260	1,210					
		300	1.12	<0.2	1,260	1,210					
		350	1.12	<0.2	1,260	970					
		400	1.12	<0.2	1,260	970					
Hardened die steel (SKD61, DAC, DHA) 42-52HRC	DH102 (JC8015)	~200	1.12	<0.15	860	690					
		250	1.12	<0.15	860	690					
		300	1.12	<0.15	860	690					
		350	1.12	<0.15	860	550					
		400	1.12	<0.15	860	550					
Grey & Nodular cast iron (FC, FCD) below 300HB	JC8015 (DH102)	~200	1.12	<0.2	2,780	3,340					
		250	1.12	<0.2	2,780	3,340					
		300	1.12	<0.2	2,780	3,340					
		350	1.12	<0.2	2,270	2,180					
		400	1.12	<0.2	2,270	2,180					

Note

1. Please adjust cutting conditions according to machine rigidity or work rigidity.
2. In case of chatter occurring, recommended to reduce ap or rpm and keep feed per tooth.
3. ap should be reduced when using on low rigidity machine.
4. Use air blow.

QM MAX**MQX/QXP Type**

■ Recommended cutting conditions

● MQX Type (YPHW-15 /-F insert) - Side finishing

4

Material	Grade	Tool dia.(mm)														
		16/17					20					20/21				
		2N					3N					4N				
		ℓ (mm)	ap (mm)	ae (mm)	n (min ⁻¹)	Vf (mm/min)	ℓ (mm)	ap (mm)	ae (mm)	n (min ⁻¹)	Vf (mm/min)	ℓ (mm)	ap (mm)	ae (mm)	n (min ⁻¹)	Vf (mm/min)
Carbon steel (S50C, S55C) below 250HB	CX75 (JC8015) (DH102)	~70	1.5	<0.2	12,900	3,870	~70	1.5	<0.2	10,300	4,640	~70	1.5	<0.2	10,300	6,190
		120	1	<0.2	8,950	2,150	120	1	<0.2	7,160	2,580	120	1	<0.2	7,160	3,440
		160	0.7	<0.2	8,950	1,790	190	0.7	<0.2	7,160	2,150	190	0.7	<0.2	7,160	2,870
Tool & die steel (SKD61, SKD11) below 255HB	CX75 (JC8015) (DH102)	~70	1.5	<0.2	8,950	2,680	~70	1.5	<0.2	7,160	3,220	~70	1.5	<0.2	7,160	4,290
		120	1	<0.2	8,950	2,150	120	1	<0.2	7,160	2,580	120	1	<0.2	7,160	3,440
		160	0.7	<0.2	6,960	1,390	190	0.7	<0.2	5,570	1,670	190	0.7	<0.2	5,570	2,230
Mold steel (HPM7, PX5, P20) 30-36 HRC	JC8015 (DH102)	~70	1.5	<0.2	8,950	2,680	~70	1.5	<0.2	7,160	3,220	~70	1.5	<0.2	7,160	4,290
		120	1	<0.2	8,950	2,150	120	1	<0.2	7,160	2,580	120	1	<0.2	7,160	3,440
		160	0.7	<0.2	6,960	1,390	190	0.7	<0.2	5,570	1,670	190	0.7	<0.2	5,570	2,230
Mold steel (NAK80, HPM1, P21) 38-43HRC	JC8015 (DH102)	~70	1.5	<0.2	7,960	1,910	~70	1.5	<0.2	6,370	2,290	~70	1.5	<0.2	6,370	3,050
		120	1	<0.2	6,960	1,390	120	1	<0.2	5,570	1,670	120	1	<0.2	5,570	2,230
		160	0.7	<0.2	6,960	1,110	190	0.7	<0.2	5,570	1,340	190	0.7	<0.2	5,570	1,790
Hardened die steel (SKD61, DAC, DHA) 42-52HRC	JC8015 (DH102)	~70	1.5	<0.2	3,980	800	~70	1.5	<0.2	3,180	950	~70	1.5	<0.2	3,180	1,270
		120	1	<0.2	3,380	540	120	1	<0.2	2,710	630	120	1	<0.2	2,710	840
		160	-	-	-	-	190	-	-	-	-	190	-	-	-	-
Hardened die steel (SKD11, SLD, DC11) 55-62HRC	DH102	~70	1	<0.2	3,580	720	~70	1	<0.2	2,860	860	~70	1	<0.2	2,860	1,150
		120	0.7	<0.2	2,980	480	120	0.7	<0.2	2,390	570	120	0.7	<0.2	2,390	760
		160	-	-	-	-	190	-	-	-	-	190	-	-	-	-
Grey & Nodular cast iron (FC, FCD) below 300HB	JC8015 (DH102)	~70	1.5	<0.2	10,900	3,270	~70	1.5	<0.2	8,750	3,940	~70	1.5	<0.2	8,750	5,250
		120	1	<0.2	8,950	2,150	120	1	<0.2	7,160	2,580	120	1	<0.2	7,160	3,440
		160	0.7	<0.2	8,950	1,790	190	0.7	<0.2	7,160	2,150	190	0.7	<0.2	7,160	2,870
Stainless steel (SUS304) below 250HB	JC8015 (DH102)	~70	1.5	<0.2	8,950	2,680	~70	1.5	<0.2	7,160	3,220	~70	1.5	<0.2	7,160	4,290
		120	1	<0.2	8,950	2,150	120	1	<0.2	7,160	2,580	120	1	<0.2	7,160	3,440
		160	0.7	<0.2	6,960	1,390	190	0.7	<0.2	5,570	1,670	190	0.7	<0.2	5,570	2,230
Titanium alloy (Ti-6Al-4V)	JC8015 (DH102)	~70	1.5	<0.2	1,790	430	~70	1.5	<0.2	1,430	520	~70	1.5	<0.2	1,430	690
		120	1	<0.2	1,390	280	120	1	<0.2	1,110	330	120	1	<0.2	1,110	440
		160	0.7	<0.2	1,390	220	190	0.7	<0.2	1,110	270	190	0.7	<0.2	1,110	360

Note

1. Please adjust cutting conditions according to machine rigidity or work rigidity.
2. In case of chatter occurring, recommended to reduce ap or rpm and keep feed per tooth.
3. ap should be reduced when using on low rigidity machine.
4. Use air blow.

QM MAX**MQX/QXP Type**

■ Recommended cutting conditions

● MQX Type (YPHW-15 /-F insert) - Side finishing

4

Material	Grade	Tool dia.(mm)									
		25/26					25/26/28				
		4N					5N				
		ℓ (mm)	a _p (mm)	a _e (mm)	n (min ⁻¹)	V _f (mm/min)	ℓ (mm)	a _p (mm)	a _e (mm)	n (min ⁻¹)	V _f (mm/min)
Carbon steel (S50C, S55C) below 250HB	CX75 (JC8015) (DH102)	~90	1.5	<0.2	8,280	4,970	~90	1.5	<0.2	8,280	6,210
		140	1	<0.2	5,730	2,750	140	1	<0.2	5,730	3,440
		210	0.7	<0.2	5,730	2,290	210	0.7	<0.2	5,730	2,860
Tool & die steel (SKD61, SKD11) below 255HB	CX75 (JC8015) (DH102)	~90	1.5	<0.2	5,730	3,440	~90	1.5	<0.2	5,730	4,300
		140	1	<0.2	5,730	2,750	140	1	<0.2	5,730	3,440
		210	0.7	<0.2	4,460	1,780	210	0.7	<0.2	4,460	2,230
Mold steel (HPM7, PX5, P20) 30-36 HRC	JC8015 (DH102)	~90	1.5	<0.2	5,730	3,440	~90	1.5	<0.2	5,730	4,300
		140	1	<0.2	5,730	2,750	140	1	<0.2	5,730	3,440
		210	0.7	<0.2	4,460	1,780	210	0.7	<0.2	4,460	2,230
Mold steel (NAK80, HPM1, P21) 38-43HRC	JC8015 (DH102)	~90	1.5	<0.2	5,090	2,440	~90	1.5	<0.2	5,090	3,050
		140	1	<0.2	4,460	1,780	140	1	<0.2	4,460	2,230
		210	0.7	<0.2	4,460	1,430	210	0.7	<0.2	4,460	1,790
Hardened die steel (SKD61, DAC, DHA) 42-52HRC	JC8015 (DH102)	~90	1.5	<0.2	2,550	1,020	~90	1.5	<0.2	2,550	1,280
		140	1	<0.2	2,160	690	140	1	<0.2	2,160	860
		210	-	-	-	-	210	-	-	-	-
Hardened die steel (SKD11, SL, DC11) 55-62HRC	DH102	~90	1	<0.2	2,290	920	~90	1	<0.2	2,290	1,150
		140	0.7	<0.2	1,910	610	140	0.7	<0.2	1,910	760
		210	-	-	-	-	210	-	-	-	-
Grey & Nodular cast iron (FC, FCD) below 300HB	JC8015 (DH102)	~90	1.5	<0.2	7,000	4,200	~90	1.5	<0.2	7,000	5,250
		140	1	<0.2	5,730	2,750	140	1	<0.2	5,730	3,440
		210	0.7	<0.2	5,730	2,290	210	0.7	<0.2	5,730	2,860
Stainless steel (SUS304) below 250HB	JC8015 (DH102)	~90	1.5	<0.2	5,730	3,440	~90	1.5	<0.2	5,730	4,300
		140	1	<0.2	5,730	2,750	140	1	<0.2	5,730	3,440
		210	0.7	<0.2	4,460	1,780	210	0.7	<0.2	4,460	2,230
Titanium alloy (Ti-6Al-4V)	JC8015 (DH102)	~90	1.5	<0.2	1,150	550	~90	1.5	<0.2	1,150	690
		140	1	<0.2	890	360	140	1	<0.2	890	450
		210	0.7	<0.2	890	280	210	0.7	<0.2	890	350

Note

1. Please adjust cutting conditions according to machine rigidity or work rigidity.
2. In case of chatter occurring, recommended to reduce a_p or rpm and keep feed per tooth.
3. a_p should be reduced when using on low rigidity machine.
4. Use air blow.

QM MAX**MQX/QXP Type**

■ Recommended cutting conditions

● MQX Type (YPHW-15 /-F insert) - Side finishing

4

Material	Grade	Tool dia.(mm)									
		30/32/35					32/35				
		5N					6N				
		ℓ (mm)	a _p (mm)	a _e (mm)	n (min ⁻¹)	V _f (mm/min)	ℓ (mm)	a _p (mm)	a _e (mm)	n (min ⁻¹)	V _f (mm/min)
Carbon steel (S50C, S55C) below 250HB	CX75 (JC8015) (DH102)	~100	1.5	<0.2	6,470	4,850	~100	1.5	<0.2	6,470	5,820
		150	1.2	<0.2	4,480	2,690	150	1.2	<0.2	4,480	3,230
		210	1	<0.2	4,480	2,240	210	1	<0.2	4,480	2,690
Tool & die steel (SKD61, SKD11) below 255HB	CX75 (JC8015) (DH102)	~100	1.5	<0.2	4,480	3,360	~100	1.5	<0.2	4,480	4,030
		150	1.2	<0.2	4,480	2,690	150	1.2	<0.2	4,480	3,230
		210	1	<0.2	3,480	1,740	210	1	<0.2	3,480	2,090
Mold steel (HPM7, PX5, P20) 30-36 HRC	JC8015 (DH102)	~100	1.5	<0.2	4,480	3,360	~100	1.5	<0.2	4,480	4,030
		150	1.2	<0.2	4,480	2,690	150	1.2	<0.2	4,480	3,230
		210	1	<0.2	3,480	1,740	210	1	<0.2	3,480	2,090
Mold steel (NAK80, HPM1, P21) 38-43HRC	JC8015 (DH102)	~100	1.5	<0.2	3,980	2,390	~100	1.5	<0.2	3,980	2,870
		150	1.2	<0.2	3,480	1,740	150	1.2	<0.2	3,480	2,090
		210	1	<0.2	3,480	1,390	210	1	<0.2	3,480	1,670
Hardened die steel (SKD61, DAC, DHA) 42-52HRC	JC8015 (DH102)	~100	1.5	<0.2	2,000	1,000	~100	1.5	<0.2	2,000	1,200
		150	1.2	<0.2	1,690	680	150	1.2	<0.2	1,690	820
		210	1	<0.2	1,690	680	210	1	<0.2	1,690	820
Hardened die steel (SKD11, SLD, DC11) 55-62HRC	DH102	~100	1	<0.2	1,790	900	~100	1	<0.2	1,790	1,080
		150	0.8	<0.2	1,490	600	150	0.8	<0.2	1,490	720
		210	0.7	<0.2	1,490	420	210	0.7	<0.2	1,490	500
Grey & Nodular cast iron (FC, FCD) below 300HB	JC8015 (DH102)	~100	1.5	<0.2	5,470	4,100	~100	1.5	<0.2	5,470	4,920
		150	1.2	<0.2	4,480	2,690	150	1.2	<0.2	4,480	3,230
		210	1	<0.2	4,480	2,240	210	1	<0.2	4,480	2,690
Stainless steel (SUS304) below 250HB	JC8015 (DH102)	~100	1.5	<0.2	4,480	3,360	~100	1.5	<0.2	4,480	4,030
		150	1.2	<0.2	4,480	2,690	150	1.2	<0.2	4,480	3,230
		210	1	<0.2	3,480	1,740	210	1	<0.2	3,480	2,090
Titanium alloy (Ti-6Al-4V)	JC8015 (DH102)	~100	1.5	<0.2	900	540	~100	1.5	<0.2	900	650
		150	1.2	<0.2	700	350	150	1.2	<0.2	700	420
		210	1	<0.2	700	280	210	1	<0.2	700	340

Note

1. Please adjust cutting conditions according to machine rigidity or work rigidity.
2. In case of chatter occurring, recommended to reduce a_p or rpm and keep feed per tooth.
3. a_p should be reduced when using on low rigidity machine.
4. Use air blow.

QM MAX**MQX/QXP Type**

■ Recommended cutting conditions

● MQX Type (YPHW-15 /-F insert) - Side finishing

4

Material	Grade	Tool dia.(mm)									
		40/42					40				
		6N					7N				
		ℓ (mm)	a _p (mm)	a _e (mm)	n (min ⁻¹)	V _f (mm/min)	ℓ (mm)	a _p (mm)	a _e (mm)	n (min ⁻¹)	V _f (mm/min)
Carbon steel (S50C, S55C) below 250HB	CX75 (JC8015) (DH102)	~100	1.5	<0.2	5,170	4,650	~100	1.5	<0.2	5,170	5,420
		150	1.5	<0.2	5,170	4,650	150	1.5	<0.2	5,170	5,420
		210	1	<0.2	3,580	2,580	210	1	<0.2	3,580	3,010
Tool & die steel (SKD61, SKD11) below 255HB	CX75 (JC8015) (DH102)	~100	1.5	<0.2	3,580	3,220	~100	1.5	<0.2	3,580	3,760
		150	1.5	<0.2	3,580	3,220	150	1.5	<0.2	3,580	3,760
		210	1	<0.2	2,790	2,010	210	1	<0.2	2,790	2,350
Mold steel (HPM7, PX5, P20) 30-36 HRC	JC8015 (DH102)	~100	1.5	<0.2	3,580	3,220	~100	1.5	<0.2	3,580	3,760
		150	1.5	<0.2	3,580	3,220	150	1.5	<0.2	3,580	3,760
		210	1	<0.2	2,790	2,010	210	1	<0.2	2,790	2,350
Mold steel (NAK80, HPM1, P21) 38-43HRC	JC8015 (DH102)	~100	1.5	<0.2	3,180	2,290	~100	1.5	<0.2	3,180	2,670
		150	1.5	<0.2	3,180	2,290	150	1.5	<0.2	3,180	2,670
		210	1	<0.2	2,790	1,670	210	1	<0.2	2,790	1,950
Hardened die steel (SKD61, DAC, DHA) 42-52HRC	JC8015 (DH102)	~100	1.5	<0.2	1,590	950	~100	1.5	<0.2	1,590	1,110
		150	1.5	<0.2	1,590	950	150	1.5	<0.2	1,350	1,110
		210	1	<0.2	1,350	650	210	1	<0.2	1,350	760
Hardened die steel (SKD11, SLD, DC11) 55-62HRC	DH102	~100	1	<0.2	1,430	860	~100	1	<0.2	1,430	1,000
		150	1	<0.2	1,430	860	150	1	<0.2	1,430	1,000
		210	0.7	<0.2	1,190	570	210	0.7	<0.2	1,190	670
Grey & Nodular cast iron (FC, FCD) below 300HB	JC8015 (DH102)	~100	1.5	<0.2	4,380	3,940	~100	1.5	<0.2	4,380	4,600
		150	1.5	<0.2	3,580	3,940	150	1.5	<0.2	3,580	4,600
		210	1	<0.2	3,580	2,580	210	1	<0.2	3,580	3,010
Stainless steel (SUS304) below 250HB	JC8015 (DH102)	~100	1.5	<0.2	3,580	3,220	~100	1.5	<0.2	3,580	3,760
		150	1.5	<0.2	3,580	3,220	150	1.5	<0.2	3,580	3,760
		210	1	<0.2	2,790	2,010	210	1	<0.2	2,790	2,350
Titanium alloy (Ti-6Al-4V)	JC8015 (DH102)	~100	1.5	<0.2	720	520	~100	1.5	<0.2	720	610
		150	1.5	<0.2	560	520	150	1.5	<0.2	560	610
		210	1	<0.2	560	340	210	1	<0.2	560	400

Note

1. Please adjust cutting conditions according to machine rigidity or work rigidity.
2. In case of chatter occurring, recommended to reduce a_p or rpm and keep feed per tooth.
3. a_p should be reduced when using on low rigidity machine.
4. Use air blow.

QM MAX

MQX/QXP Type

■ Recommended cutting conditions

● QXP Type (YPHW-15 /-F insert) - Side finishing

4

Material	Grade	Tool dia.(mm)									
		40									
		6N					7N				
		ℓ (mm)	a_p (mm)	a_e (mm)	n (min ⁻¹)	V_f (mm/min)	ℓ (mm)	a_p (mm)	a_e (mm)	n (min ⁻¹)	V_f (mm/min)
Carbon steel (S50C, S55C) below 250HB	CX75 (JC8015) (DH102)	~150	1.5	<0.2	5,170	4,650	~150	1.5	<0.2	5,170	5,430
		200	1.5	<0.2	5,170	4,650	200	1.5	<0.2	5,170	5,430
		250	1	<0.2	3,580	2,580	250	1	<0.2	3,580	3,010
		300	0.7	<0.2	3,580	2,360	300	0.7	<0.2	3,580	2,750
		350	-	-	-	-	350	-	-	-	-
Tool & die steel (SKD61, SKD11) below 255HB	CX75 (JC8015) (DH102)	~150	1.5	<0.2	3,580	3,220	~150	1.5	<0.2	3,580	3,760
		200	1.5	<0.2	3,580	3,220	200	1.5	<0.2	3,580	3,760
		250	1	<0.2	2,790	2,010	250	1	<0.2	2,790	2,350
		300	0.7	<0.2	2,790	1,670	300	0.7	<0.2	2,790	1,950
		350	-	-	-	-	350	-	-	-	-
Mold steel (HPM7, PX5, P20) 30-36 HRC	JC8015 (DH102)	~150	1.5	<0.2	3,580	3,220	~150	1.5	<0.2	3,580	3,760
		200	1.5	<0.2	3,580	3,220	200	1.5	<0.2	3,580	3,760
		250	1	<0.2	2,790	2,010	250	1	<0.2	2,790	2,350
		300	0.7	<0.2	2,790	1,670	300	0.7	<0.2	2,790	1,950
		350	-	-	-	-	350	-	-	-	-
Mold steel (NAK80, HPM1, P21) 38-43HRC	JC8015 (DH102)	~150	1.5	<0.2	3,180	2,290	~150	1.5	<0.2	3,180	2,670
		200	1.5	<0.2	3,180	2,290	200	1.5	<0.2	3,180	2,670
		250	1	<0.2	2,790	1,670	250	1	<0.2	2,790	1,950
		300	0.7	<0.2	2,790	1,340	300	0.7	<0.2	2,790	1,560
		350	-	-	-	-	350	-	-	-	-
Hardened die steel (SKD61, DAC, DHA) 42-52HRC	JC8015 (DH102)	~150	1.5	<0.2	1,590	950	~150	1.5	<0.2	1,590	1,110
		200	1.5	<0.2	1,590	950	200	1.5	<0.2	1,590	1,110
		250	1	<0.2	1,350	650	250	1	<0.2	1,350	760
		300	0.7	<0.2	1,350	650	300	0.7	<0.2	1,350	760
		350	-	-	-	-	350	-	-	-	-
Hardened die steel (SKD11, SLD, DC11) 55-62HRC	DH102	~150	1	<0.2	1,430	860	~150	1	<0.2	1,430	1,000
		200	1	<0.2	1,430	860	200	1	<0.2	1,430	1,000
		250	0.7	<0.2	1,190	570	250	0.7	<0.2	1,190	670
		300	0.5	<0.2	1,190	360	300	0.5	<0.2	1,190	420
		350	-	-	-	-	350	-	-	-	-
Gery & Nodular cast iron (FC, FCD) below 300HB	JC8015 (DH102)	~150	1.5	<0.2	4,380	3,940	~150	1.5	<0.2	4,380	4,600
		200	1.5	<0.2	4,380	3,940	200	1.5	<0.2	4,380	4,600
		250	1	<0.2	3,580	2,580	250	1	<0.2	3,580	3,010
		300	0.7	<0.2	3,580	2,150	300	0.7	<0.2	3,580	2,510
		350	-	-	-	-	350	-	-	-	-
Stainless steel (SUS304) below 250HB	JC8015 (DH102)	~150	1.5	<0.2	3,580	3,220	~150	1.5	<0.2	3,580	3,760
		200	1.5	<0.2	3,580	3,220	200	1.5	<0.2	3,580	3,760
		250	1	<0.2	2,790	2,010	250	1	<0.2	2,790	2,350
		300	0.7	<0.2	2,790	1,670	300	0.7	<0.2	2,790	1,950
		350	-	-	-	-	350	-	-	-	-
Titanium alloy (Ti-6Al-4V)	JC8015 (DH102)	~150	1.5	<0.2	720	520	~150	1.5	<0.2	720	610
		200	1.5	<0.2	720	520	200	1.5	<0.2	720	610
		250	1	<0.2	560	340	250	1	<0.2	560	400
		300	0.7	<0.2	560	270	300	0.7	<0.2	560	320
		350	-	-	-	-	350	-	-	-	-

Note

1. Please adjust cutting conditions according to machine rigidity or work rigidity.
2. In case of chatter occurring, recommended to reduce a_p or rpm and keep feed per tooth.
3. a_p should be reduced when using on low rigidity machine.
4. Use air blow.

QM MAX**MQX/QXP Type**

■ Recommended cutting conditions

● QXP Type (YPHW-15 /-F insert) - Side finishing

4

Material	Grade	Tool dia.(mm)									
		50 7N					50/52 8N				
		φ (mm)	ap (mm)	ae (mm)	n (min ⁻¹)	Vf (mm/min)	φ (mm)	ap (mm)	ae (mm)	n (min ⁻¹)	Vf (mm/min)
Carbon steel (S50C, S55C) below 250HB	CX75 (JC8015) (DH102)	~150	2	<0.2	4,140	4,350	~150	2	<0.2	4,140	4,970
		200	2	<0.2	4,140	4,350	200	2	<0.2	4,140	4,970
		250	2	<0.2	4,140	4,350	250	2	<0.2	4,140	4,970
		300	1.5	<0.2	2,860	2,400	300	1.5	<0.2	2,860	2,740
		350	1.5	<0.2	2,860	2,400	350	1.5	<0.2	2,860	2,740
Tool & die steel (SKD61, SKD11) below 255HB	CX75 (JC8015) (DH102)	~150	2	<0.2	2,860	3,000	~150	2	<0.2	2,860	3,430
		200	2	<0.2	2,860	3,000	200	2	<0.2	2,860	3,430
		250	2	<0.2	2,860	3,000	250	2	<0.2	2,860	3,430
		300	1.5	<0.2	2,860	2,400	300	1.5	<0.2	2,860	2,740
		350	1.5	<0.2	2,860	2,400	350	1.5	<0.2	2,860	2,740
Mold steel (HPM7, PX5, P20) 30-36 HRC	JC8015 (DH102)	~150	2	<0.2	2,860	3,000	~150	2	<0.2	2,860	3,430
		200	2	<0.2	2,860	3,000	200	2	<0.2	2,860	3,430
		250	2	<0.2	2,860	3,000	250	2	<0.2	2,860	3,430
		300	1.5	<0.2	2,860	2,400	300	1.5	<0.2	2,860	2,740
		350	1.5	<0.2	2,860	2,400	350	1.5	<0.2	2,860	2,740
Mold steel (NAK80, HPM1, P21) 38-43HRC	JC8015 (DH102)	~150	2	<0.2	2,550	2,140	~150	2	<0.2	2,550	2,450
		200	2	<0.2	2,550	2,140	200	2	<0.2	2,550	2,450
		250	2	<0.2	2,550	2,140	250	2	<0.2	2,550	2,450
		300	1.5	<0.2	2,230	1,560	300	1.5	<0.2	2,230	1,780
		350	1.5	<0.2	2,230	1,560	350	1.5	<0.2	2,230	1,780
Hardened die steel (SKD61, DAC, DHA) 42-52HRC	JC8015 (DH102)	~150	1.5	<0.2	1,270	890	~150	1.5	<0.2	1,270	1,020
		200	1.5	<0.2	1,270	890	200	1.5	<0.2	1,270	1,020
		250	1.5	<0.2	1,270	890	250	1.5	<0.2	1,270	1,020
		300	1.2	<0.2	1,080	600	300	1.2	<0.2	1,080	690
		350	1.2	<0.2	1,080	600	350	1.2	<0.2	1,080	690
Hardened die steel (SKD11, SL D, DC11) 55-62HRC	DH102	~150	1.5	<0.2	1,150	810	~150	1.5	<0.2	1,150	930
		200	1.5	<0.2	1,150	810	200	1.5	<0.2	1,150	930
		250	1.5	<0.2	1,150	810	250	1.5	<0.2	1,150	930
		300	1	<0.2	950	530	300	1	<0.2	950	610
		350	1	<0.2	950	530	350	1	<0.2	950	610
Grey & Nodular cast iron (FC, FCD) below 300HB	JC8015 (DH102)	~150	2	<0.2	3,500	3,680	~150	2	<0.2	3,500	4,210
		200	2	<0.2	3,500	3,680	200	2	<0.2	3,500	4,210
		250	2	<0.2	3,500	3,680	250	2	<0.2	3,500	4,210
		300	1.5	<0.2	2,860	2,400	300	1.5	<0.2	2,860	2,740
		350	1.5	<0.2	2,860	2,400	350	1.5	<0.2	2,860	2,740
Stainless steel (SUS304) below 250HB	JC8015 (DH102)	~150	2	<0.2	2,860	3,000	~150	2	<0.2	2,860	3,430
		200	2	<0.2	2,860	3,000	200	2	<0.2	2,860	3,430
		250	2	<0.2	2,860	3,000	250	2	<0.2	2,860	3,430
		300	1.5	<0.2	2,860	2,400	300	1.5	<0.2	2,860	2,740
		350	1.5	<0.2	2,860	2,400	350	1.5	<0.2	2,860	2,740
Titanium alloy (Ti-6Al-4V)	JC8015 (DH102)	~150	2	<0.2	570	480	~150	2	<0.2	570	550
		200	2	<0.2	570	480	200	2	<0.2	570	550
		250	2	<0.2	570	480	250	2	<0.2	570	550
		300	1.5	<0.2	450	320	300	1.5	<0.2	450	370
		350	1.5	<0.2	450	320	350	1.5	<0.2	450	370

Note

1. Please adjust cutting conditions according to machine rigidity or work rigidity.
2. In case of chatter occurring, recommended to reduce ap or rpm and keep feed per tooth.
3. ap should be reduced when using on low rigidity machine.
4. Use air blow.

QM MAX**MQX/QXP Type**

■ Recommended cutting conditions

● QXP Type (YPHW-15 /-F insert) - Side finishing

4

Material	Grade	Tool dia.(mm)									
		63/66									
		8N									
ϕ (mm)	a_p (mm)	a_e (mm)	n (min ⁻¹)	V_f (mm/min)							
Carbon steel (S50C, S55C) below 250HB	CX75 (JC8015) (DH102)	~200	2	<0.2	3,290	3,950					
		250	2	<0.2	3,290	3,950					
		300	2	<0.2	3,290	3,950					
		350	1.5	<0.2	2,270	2,180					
		400	1.5	<0.2	2,270	2,180					
Tool & die steel (SKD61, SKD11) below 255HB	CX75 (JC8015) (DH102)	~200	2	<0.2	2,270	2,720					
		250	2	<0.2	2,270	2,720					
		300	2	<0.2	2,270	2,720					
		350	1.5	<0.2	2,270	2,180					
		400	1.5	<0.2	2,270	2,180					
Mold steel (HPM7, PX5, P20) 30-36 HRC	JC8015 (DH102)	~200	2	<0.2	2,270	2,720					
		250	2	<0.2	2,270	2,720					
		300	2	<0.2	2,270	2,720					
		350	1.5	<0.2	2,270	2,180					
		400	1.5	<0.2	2,270	2,180					
Mold steel (NAK80, HPM1, P21) 38-43HRC	JC8015 (DH102)	~200	2	<0.2	2,020	1,940					
		250	2	<0.2	2,020	1,940					
		300	2	<0.2	2,020	1,940					
		350	1.5	<0.2	1,770	1,410					
		400	1.5	<0.2	1,770	1,410					
Hardened die steel (SKD61, DAC, DHA) 42-52HRC	JC8015 (DH102)	~200	1.5	<0.2	1,010	810					
		250	1.5	<0.2	1,010	810					
		300	1.5	<0.2	1,010	810					
		350	1.2	<0.2	860	550					
		400	1.2	<0.2	860	550					
Hardened die steel (SKD11, SLD, DC11) 55-62HRC	DH102	~200	1.5	<0.2	910	740					
		250	1.5	<0.2	910	740					
		300	1.5	<0.2	910	740					
		350	1	<0.2	750	480					
		400	1	<0.2	750	480					
Grey & Nodular cast iron (FC, FCD) below 300HB	JC8015 (DH102)	~200	2	<0.2	2,780	3,340					
		250	2	<0.2	2,780	3,340					
		300	2	<0.2	2,780	3,340					
		350	1.5	<0.2	2,270	2,180					
		400	1.5	<0.2	2,270	2,180					
Stainless steel (SUS304) below 250HB	JC8015 (DH102)	~200	2	<0.2	2,270	2,720					
		250	2	<0.2	2,270	2,720					
		300	2	<0.2	2,270	2,720					
		350	1.5	<0.2	2,270	2,180					
		400	1.5	<0.2	2,270	2,180					
Titanium alloy (Ti-6Al-4V)	JC8015 (DH102)	~200	2	<0.2	450	440					
		250	2	<0.2	450	440					
		300	2	<0.2	450	440					
		350	1.5	<0.2	360	300					
		400	1.5	<0.2	360	300					

Note

1. Please adjust cutting conditions according to machine rigidity or work rigidity.
2. In case of chatter occurring, recommended to reduce a_p or rpm and keep feed per tooth.
3. a_p should be reduced when using on low rigidity machine.
4. Use air blow.

QM MAX**MQX/QXP Type**

■ Recommended cutting conditions

● MQX Type (YPHW-15 insert) - Bottom finishing

4

Material	Grade	Tool dia.(mm)														
		16/17					20					20/21				
		2N					3N					4N				
		ℓ (mm)	a _p (mm)	a _e (mm)	n (min ⁻¹)	V _f (mm/min)	ℓ (mm)	a _p (mm)	a _e (mm)	n (min ⁻¹)	V _f (mm/min)	ℓ (mm)	a _p (mm)	a _e (mm)	n (min ⁻¹)	V _f (mm/min)
Carbon steel (S50C, S55C) below 250HB	CX75 (DH102)	~70	0.2	8~16	5,200	2,600	~70	0.2	10~20	4,200	3,150	~70	0.2	10~18	4,200	4,200
		120	0.2	8~16	3,900	1,550	120	0.2	10~20	3,200	1,950	120	0.2	10~18	3,200	2,550
		160	0.2	8~10	3,400	1,200	190	0.2	10~12	2,700	1,450	190	0.2	10~12	2,700	1,900
Tool & die steel (SKD61, SKD11) below 255HB	CX75 (DH102)	~70	0.2	8~16	4,700	2,100	~70	0.2	10~20	3,800	2,550	~70	0.2	10~18	3,800	3,400
		120	0.2	8~16	3,500	1,400	120	0.2	10~20	2,900	1,750	120	0.2	10~18	2,900	2,350
		160	0.2	8~10	3,000	1,100	190	0.2	10~12	2,450	1,300	190	0.2	10~12	2,450	1,750
Mold steel (HPM7, PX5, P20) 30-36 HRC	DH102	~70	0.2	8~16	4,350	1,750	~70	0.2	10~20	3,500	2,100	~70	0.2	10~18	3,500	2,800
		120	0.2	8~16	3,250	1,200	120	0.2	10~20	2,650	1,450	120	0.2	10~18	2,650	1,950
		160	0.2	8~10	2,750	950	190	0.2	10~12	2,250	1,150	190	0.2	10~12	2,250	1,500
Mold steel (NAK80, HPM1, P21) 38-43HRC	DH102	~70	0.2	8~16	4,000	960	~70	0.2	10~20	3,200	1,150	~70	0.2	10~18	3,200	1,500
		120	0.2	8~16	3,000	600	120	0.2	10~20	2,400	720	120	0.2	10~18	2,400	960
		160	0.2	8~10	2,550	500	190	0.2	10~12	2,050	600	190	0.2	10~12	2,050	800
Hardened die steel (SKD61, DAC, DHA) 42-52HRC	DH102	~70	0.2	8~16	2,000	400	~70	0.2	10~20	1,600	480	~70	0.2	10~18	1,600	640
		120	0.2	8~16	1,600	320	120	0.2	10~20	1,280	380	120	0.2	10~18	1,280	510
		160	-	-	-	-	190	-	-	-	-	190	-	-	-	-
Hardened die steel (SKD11, SLD, DC11) 55-62HRC	DH102	~70	0.2	8~16	1,400	200	~70	0.2	10~20	1,120	240	~70	0.2	10~18	1,120	320
		120	0.2	8~16	1,000	100	120	0.2	10~20	800	120	120	0.2	10~18	800	160
		160	-	-	-	-	190	-	-	-	-	190	-	-	-	-
Grey & Nodular cast iron (FC, FCD) below 300HB	DH102	~70	0.2	8~16	4,000	1,600	~70	0.2	10~20	3,180	1,910	~70	0.2	10~18	3,180	2,540
		120	0.2	8~16	3,000	900	120	0.2	10~20	2,390	1,080	120	0.2	10~18	2,390	1,430
		160	0.2	8~10	2,600	520	190	0.2	10~12	2,070	630	190	0.2	10~12	2,070	830
Stainless steel (SUS304) below 250HB	JC8015 (DH102)	~70	0.2	8~16	3,600	1,080	~70	0.2	10~20	2,860	1,290	~70	0.2	10~18	2,860	1,720
		120	0.2	8~16	2,600	620	120	0.2	10~20	2,070	750	120	0.2	10~18	2,070	1,000
		160	0.2	8~10	2,000	400	190	0.2	10~12	1,590	480	190	0.2	10~12	1,590	640
Titanium alloy (Ti-6Al-4V)	DH102	~70	0.2	8~16	1,000	300	~70	0.2	10~20	800	360	~70	0.2	10~18	800	480
		120	0.2	8~16	600	120	120	0.2	10~20	480	150	120	0.2	10~18	480	200
		160	0.2	8~10	600	120	190	0.2	10~12	480	150	190	0.2	10~12	480	200

Note

1. Please adjust cutting conditions according to machine rigidity or work rigidity.
2. In case of chatter occurring, recommended to reduce a_p or rpm and keep feed per tooth.
3. a_p should be reduced when using on low rigidity machine.
4. Use air blow.
5. YPHW-F insert with lower feed is recommended for better surface finish in case chatter occurs.
Please scan QR code for cutting conditions of YPHW-F /-24 for bottom finishing.



QM MAX**MQX/QXP Type**

■ Recommended cutting conditions

● MQX Type (YPHW-15 insert) - Bottom finishing

4

Material	Grade	Tool dia.(mm)									
		25/26					25/26/28				
		4N					5N				
		ℓ (mm)	a _p (mm)	a _e (mm)	n (min ⁻¹)	V _f (mm/min)	ℓ (mm)	a _p (mm)	a _e (mm)	n (min ⁻¹)	V _f (mm/min)
Carbon steel (S50C, S55C) below 250HB	CX75 (DH102)	~90	0.2	12.5~25	3,400	3,400	~90	0.2	12.5~22	3,400	4,250
		140	0.2	12.5~25	2,500	2,000	140	0.2	12.5~22	2,500	2,500
		210	0.2	12.5~15	2,200	1,550	210	0.2	12.5~15	2,200	1,900
Tool & die steel (SKD61, SKD11) below 255HB	CX75 (DH102)	~90	0.2	12.5~25	3,050	2,750	~90	0.2	12.5~22	3,050	3,400
		140	0.2	12.5~25	2,250	1,800	140	0.2	12.5~22	2,250	2,250
		210	0.2	12.5~15	2,000	1,400	210	0.2	12.5~15	2,000	1,750
Mold steel (HPM7, PX5, P20) 30-36 HRC	DH102	~90	0.2	12.5~25	2,800	2,250	~90	0.2	12.5~22	2,800	2,800
		140	0.2	12.5~25	2,100	1,500	140	0.2	12.5~22	2,100	1,900
		210	0.2	12.5~15	1,800	1,200	210	0.2	12.5~15	1,800	1,500
Mold steel (NAK80, HPM1, P21) 38-43HRC	DH102	~90	0.2	12.5~25	2,550	1,250	~90	0.2	12.5~22	2,550	1,500
		140	0.2	12.5~25	1,900	750	140	0.2	12.5~22	1,900	950
		210	0.2	12.5~15	1,650	650	210	0.2	12.5~15	1,650	850
Hardened die steel (SKD61, DAC, DHA) 42-52HRC	DH102	~90	0.2	12.5~25	1,270	510	~90	0.2	12.5~22	1,270	640
		140	0.2	12.5~25	1,020	410	140	0.2	12.5~22	1,020	510
		210	-	-	-	-	210	-	-	-	-
Hardened die steel (SKD11, SLD, DC11) 55-62HRC	DH102	~90	0.2	12.5~25	890	250	~90	0.2	12.5~22	890	310
		140	0.2	12.5~25	640	130	140	0.2	12.5~22	640	160
		210	-	-	-	-	210	-	-	-	-
Grey & Nodular cast iron (FC, FCD) below 300HB	DH102	~90	0.2	12.5~25	2,550	2,040	~90	0.2	12.5~22	2,550	2,550
		140	0.2	12.5~25	1,910	1,150	140	0.2	12.5~22	1,910	1,440
		210	0.2	12.5~15	1,660	660	210	0.2	12.5~15	1,660	820
Stainless steel (SUS304) below 250HB	JC8015 (DH102)	~90	0.2	12.5~25	2,290	1,370	~90	0.2	12.5~22	2,290	1,710
		140	0.2	12.5~25	1,660	800	140	0.2	12.5~22	1,660	1,000
		210	0.2	12.5~15	1,270	510	210	0.2	12.5~15	1,270	640
Titanium alloy (Ti-6Al-4V)	DH102	~90	0.2	12.5~25	640	380	~90	0.2	12.5~22	640	480
		140	0.2	12.5~25	380	150	140	0.2	12.5~22	380	190
		210	0.2	12.5~15	380	150	210	0.2	12.5~15	380	190

Note

1. Please adjust cutting conditions according to machine rigidity or work rigidity.
2. In case of chatter occurring, recommended to reduce a_p or rpm and keep feed per tooth.
3. a_p should be reduced when using on low rigidity machine.
4. Use air blow.
5. YPHW-F insert with lower feed is recommended for better surface finish in case chatter occurs.
Please scan QR code for cutting conditions of YPHW-F /-24 for bottom finishing.



QM MAX**MQX/QXP Type**

■ Recommended cutting conditions

● MQX Type (YPHW-15 insert) - Bottom finishing

4

Material	Grade	Tool dia.(mm)									
		30/32/35					32/35				
		5N					6N				
		ℓ (mm)	a_p (mm)	a_e (mm)	n (min ⁻¹)	V_f (mm/min)	ℓ (mm)	a_p (mm)	a_e (mm)	n (min ⁻¹)	V_f (mm/min)
Carbon steel (S50C, S55C) below 250HB	CX75 (DH102)	~100	0.2	16~32	2,650	3,300	~100	0.2	16~30	2,650	3,950
		150	0.2	16~32	2,650	3,300	150	0.2	16~30	2,650	3,950
		210	0.2	16~32	2,000	2,000	210	0.2	16~30	2,000	2,400
Tool & die steel (SKD61, SKD11) below 255HB	CX75 (DH102)	~100	0.2	16~32	2,400	2,700	~100	0.2	16~30	2,400	3,200
		150	0.2	16~32	2,400	2,700	150	0.2	16~30	2,400	3,200
		210	0.2	16~32	1,800	1,800	210	0.2	16~30	1,800	2,150
Mold steel (HPM7, PX5, P20) 30-36 HRC	DH102	~100	0.2	16~32	2,200	2,200	~100	0.2	16~30	2,200	2,600
		150	0.2	16~32	2,200	2,200	150	0.2	16~30	2,200	2,600
		210	0.2	16~32	1,650	1,500	210	0.2	16~30	1,650	1,800
Mold steel (NAK80, HPM1, P21) 38-43HRC	DH102	~100	0.2	16~32	2,000	1,200	~100	0.2	16~30	2,000	1,450
		150	0.2	16~32	2,000	1,200	150	0.2	16~30	2,000	1,450
		210	0.2	16~32	1,500	750	210	0.2	16~30	1,500	900
Hardened die steel (SKD61, DAC, DHA) 42-52HRC	DH102	~100	0.2	16~32	1,000	500	~100	0.2	16~30	1,000	600
		150	0.2	16~32	1,000	500	150	0.2	16~30	1,000	600
		210	0.2	16~20	800	400	210	0.2	16~20	800	480
Hardened die steel (SKD11, SLD, DC11) 55-62HRC	DH102	~100	0.2	16~32	700	250	~100	0.2	16~30	700	300
		150	0.2	16~32	700	250	150	0.2	16~30	700	300
		210	0.2	16~20	500	130	210	0.2	16~20	500	160
Grey & Nodular cast iron (FC, FCD) below 300HB	DH102	~100	0.2	16~32	1,990	1,990	~100	0.2	16~30	1,990	2,390
		150	0.2	16~32	1,990	1,990	150	0.2	16~30	1,990	2,390
		210	0.2	16~32	1,490	1,120	210	0.2	16~30	1,490	1,340
Stainless steel (SUS304) below 250HB	JC8015 (DH102)	~100	0.2	16~32	1,790	1,340	~100	0.2	16~30	1,790	1,610
		150	0.2	16~32	1,790	1,340	150	0.2	16~30	1,790	1,610
		210	0.2	16~32	1,290	770	210	0.2	16~30	1,290	920
Titanium alloy (Ti-6Al-4V)	DH102	~100	0.2	16~32	500	380	~100	0.2	16~30	500	460
		150	0.2	16~32	500	380	150	0.2	16~30	500	460
		210	0.2	16~20	300	150	210	0.2	16~20	300	180

Note

1. Please adjust cutting conditions according to machine rigidity or work rigidity.
2. In case of chatter occurring, recommended to reduce a_p or rpm and keep feed per tooth.
3. a_p should be reduced when using on low rigidity machine.
4. Use air blow.
5. YPHW-F insert with lower feed is recommended for better surface finish in case chatter occurs.
Please scan QR code for cutting conditions of YPHW-F /-24 for bottom finishing.



QM MAX**MQX/QXP Type**

■ Recommended cutting conditions

● MQX Type (YPHW-15 insert) - Bottom finishing

4

Material	Grade	Tool dia.(mm)									
		40/42					40				
		6N					7N				
		ϕ (mm)	a_p (mm)	a_e (mm)	n (min ⁻¹)	V_f (mm/min)	ϕ (mm)	a_p (mm)	a_e (mm)	n (min ⁻¹)	V_f (mm/min)
Carbon steel (S50C, S55C) below 250HB	CX75 (DH102)	~100	0.2	20~40	2,100	3,150	~100	0.2	20~38	2,100	3,650
		150	0.2	20~40	2,100	3,150	150	0.2	20~38	2,100	3,650
		210	0.2	20~40	1,570	1,900	210	0.2	20~38	1,570	2,200
Tool & die steel (SKD61, SKD11) below 255HB	CX75 (DH102)	~100	0.2	20~40	1,890	2,850	~100	0.2	20~38	1,890	3,300
		150	0.2	20~40	1,890	2,850	150	0.2	20~38	1,890	3,300
		210	0.2	20~40	1,410	1,700	210	0.2	20~38	1,410	2,000
Mold steel (HPM7, PX5, P20) 30-36 HRC	DH102	~100	0.2	20~40	1,750	2,100	~100	0.2	20~38	1,750	2,450
		150	0.2	20~40	1,750	2,100	150	0.2	20~38	1,750	2,450
		210	0.2	20~40	1,300	1,400	210	0.2	20~38	1,300	1,650
Mold steel (NAK80, HPM1, P21) 38-43HRC	DH102	~100	0.2	20~40	1,600	1,150	~100	0.2	20~38	1,600	1,350
		150	0.2	20~40	1,600	1,150	150	0.2	20~38	1,600	1,350
		210	0.2	20~40	1,200	720	210	0.2	20~38	1,200	840
Hardened die steel (SKD61, DAC, DHA) 42-52HRC	DH102	~100	0.2	20~40	800	480	~100	0.2	20~38	800	560
		150	0.2	20~40	800	480	150	0.2	20~38	800	560
		210	0.2	20~40	640	380	210	0.2	20~38	640	440
Hardened die steel (SKD11, SLD, DC11) 55-62HRC	DH102	~100	0.2	20~40	560	240	~100	0.2	20~38	560	280
		150	0.2	20~40	560	240	150	0.2	20~38	560	280
		210	0.2	20~40	400	120	210	0.2	20~38	400	140
Grey & Nodular cast iron (FC, FCD) below 300HB	DH102	~100	0.2	20~40	1,590	1,910	~100	0.2	20~38	1,590	2,230
		150	0.2	20~40	1,590	1,910	150	0.2	20~38	1,590	2,230
		210	0.2	20~40	1,190	1,070	210	0.2	20~38	1,190	1,250
Stainless steel (SUS304) below 250HB	JC8015 (DH102)	~100	0.2	20~40	1,430	1,290	~100	0.2	20~38	1,430	1,500
		150	0.2	20~40	1,430	1,290	150	0.2	20~38	1,430	1,500
		210	0.2	20~40	1,030	740	210	0.2	20~38	1,030	870
Titanium alloy (Ti-6Al-4V)	DH102	~100	0.2	20~40	400	360	~100	0.2	20~38	400	420
		150	0.2	20~40	400	360	150	0.2	20~38	400	420
		210	0.2	20~40	240	140	210	0.2	20~38	240	170

Note

1. Please adjust cutting conditions according to machine rigidity or work rigidity.
2. In case of chatter occurring, recommended to reduce a_p or rpm and keep feed per tooth.
3. a_p should be reduced when using on low rigidity machine.
4. Use air blow.
5. YPHW-F insert with lower feed is recommended for better surface finish in case chatter occurs.
Please scan QR code for cutting conditions of YPHW-F /-24 for bottom finishing.



QM MAX**MQX/QXP Type**

■ Recommended cutting conditions

● QXP Type (YPHW-15 insert) - Bottom finishing

4

Material	Grade	Tool dia.(mm)									
		40									
		6N					7N				
		ϕ (mm)	a_p (mm)	a_e (mm)	n (min ⁻¹)	V_f (mm/min)	ϕ (mm)	a_p (mm)	a_e (mm)	n (min ⁻¹)	V_f (mm/min)
Carbon steel (S50C, S55C) below 250HB	CX75 (DH102)	~150	0.2	20~40	2,100	3,150	~150	0.2	20~38	2,100	3,680
		200	0.2	20~40	2,100	3,150	200	0.2	20~38	2,100	3,680
		250	0.2	20~40	1,570	1,890	250	0.2	20~38	1,570	2,200
		300	0.2	20~22	1,360	1,640	300	0.2	20~22	1,360	1,900
		350	-	-	-	-	350	-	-	-	-
Tool & die steel (SKD61, SKD11) below 255HB	CX75 (DH102)	~150	0.2	20~40	1,890	2,830	~150	0.2	20~38	1,890	3,300
		200	0.2	20~40	1,890	2,830	200	0.2	20~38	1,890	3,300
		250	0.2	20~40	1,410	1,700	250	0.2	20~38	1,410	1,980
		300	0.2	20~22	1,220	1,470	300	0.2	20~22	1,220	1,710
		350	-	-	-	-	350	-	-	-	-
Mold steel (HPM7, PX5, P20) 30-36 HRC	DH102	~150	0.2	20~40	1,750	2,100	~150	0.2	20~38	1,750	2,450
		200	0.2	20~40	1,750	2,100	200	0.2	20~38	1,750	2,450
		250	0.2	20~40	1,300	1,400	250	0.2	20~38	1,300	1,650
		300	0.2	20~22	1,150	1,150	300	0.2	20~22	1,150	1,350
		350	-	-	-	-	350	-	-	-	-
Mold steel (NAK80, HPM1, P21) 38-43HRC	DH102	~150	0.2	20~40	1,600	1,150	~150	0.2	20~38	1,600	1,350
		200	0.2	20~40	1,600	1,150	200	0.2	20~38	1,600	1,350
		250	0.2	20~40	1,200	720	250	0.2	20~38	1,200	840
		300	0.2	20~22	1,050	630	300	0.2	20~22	1,050	740
		350	-	-	-	-	350	-	-	-	-
Hardened die steel (SKD61, DAC, DHA) 42-52HRC	DH102	~150	0.2	20~40	800	480	~150	0.2	20~38	800	560
		200	0.2	20~40	800	480	200	0.2	20~38	800	560
		250	0.2	20~40	640	380	250	0.2	20~38	640	440
		300	0.2	20~22	400	120	300	0.2	20~22	400	140
		350	-	-	-	-	350	-	-	-	-
Hardened die steel (SKD11, SLD, DC11) 55-62HRC	DH102	~150	0.2	20~40	560	240	~150	0.2	20~38	560	280
		200	0.2	20~40	560	240	200	0.2	20~38	560	280
		250	0.2	20~40	400	120	250	0.2	20~38	400	140
		300	0.2	20~22	400	120	300	0.2	20~22	400	140
		350	-	-	-	-	350	-	-	-	-
Grey & Nodular cast iron (FC, FCD) below 300HB	DH102	~150	0.2	20~40	1,590	1,910	~150	0.2	20~38	1,590	2,230
		200	0.2	20~40	1,590	1,910	200	0.2	20~38	1,590	2,230
		250	0.2	20~40	1,190	1,070	250	0.2	20~38	1,190	1,250
		300	0.2	20~22	1,030	620	300	0.2	20~22	1,030	720
		350	-	-	-	-	350	-	-	-	-
Stainless steel (SUS304) below 250HB	JC8015 (DH102)	~150	0.2	20~40	1,430	1,290	~150	0.2	20~38	1,430	1,500
		200	0.2	20~40	1,430	1,290	200	0.2	20~38	1,430	1,500
		250	0.2	20~40	1,030	740	250	0.2	20~38	1,030	870
		300	0.2	20~22	800	480	300	0.2	20~22	800	560
		350	-	-	-	-	350	-	-	-	-
Titanium alloy (Ti-6Al-4V)	DH102	~150	0.2	20~40	400	360	~150	0.2	20~38	400	420
		200	0.2	20~40	400	360	200	0.2	20~38	400	420
		250	0.2	20~40	240	140	250	0.2	20~22	240	160
		300	0.2	20~22	240	140	300	0.2	20~22	240	160
		350	-	-	-	-	350	-	-	-	-

Note

1. Please adjust cutting conditions according to machine rigidity or work rigidity.
2. In case of chatter occurring, recommended to reduce a_p or rpm and keep feed per tooth.
3. a_p should be reduced when using on low rigidity machine.
4. Use air blow.
5. YPHW-F insert with lower feed is recommended for better surface finish in case chatter occurs.
Please scan QR code for cutting conditions of YPHW-F /-24 for bottom finishing.



QM MAX**MQX/QXP Type**

■ Recommended cutting conditions

● QXP Type (YPHW-15 insert) - Bottom finishing

4

Material	Grade	Tool dia.(mm)									
		50					50/52				
		7N					8N				
		ℓ (mm)	a_p (mm)	a_e (mm)	n (min ⁻¹)	V_f (mm/min)	ℓ (mm)	a_p (mm)	a_e (mm)	n (min ⁻¹)	V_f (mm/min)
Carbon steel (S50C, S55C) below 250HB	CX75 (DH102)	~150	0.2	25~50	1,700	2,970	~150	0.2	25~48	1,700	3,390
		200	0.2	25~50	1,700	2,970	200	0.2	25~48	1,700	3,390
		250	0.2	25~50	1,700	2,700	250	0.2	25~48	1,700	3,080
		300	0.2	25~50	1,280	1,790	300	0.2	25~48	1,280	2,040
		350	0.2	25~28	1,280	1,790	350	0.2	25~28	1,280	2,040
Tool & die steel (SKD61, SKD11) below 255HB	CX75 (DH102)	~150	0.2	25~50	1,530	2,670	~150	0.2	25~48	1,530	3,050
		200	0.2	25~50	1,530	2,670	200	0.2	25~48	1,530	3,050
		250	0.2	25~50	1,530	2,430	250	0.2	25~48	1,530	2,770
		300	0.2	25~50	1,150	1,600	300	0.2	25~48	1,150	1,830
		350	0.2	25~28	1,150	1,600	350	0.2	25~28	1,150	1,830
Mold steel (HPM7, PX5, P20) 30-36 HRC	DH102	~150	0.2	25~50	1,400	1,950	~150	0.2	25~48	1,400	2,200
		200	0.2	25~50	1,400	1,950	200	0.2	25~48	1,400	2,200
		250	0.2	25~50	1,400	1,750	250	0.2	25~48	1,400	2,000
		300	0.2	25~50	1,050	1,250	300	0.2	25~48	1,050	1,400
		350	0.2	25~28	1,050	1,250	350	0.2	25~28	1,050	1,400
Mold steel (NAK80, HPM1, P21) 38-43HRC	DH102	~150	0.2	25~50	1,250	1,050	~150	0.2	25~48	1,250	1,200
		200	0.2	25~50	1,250	1,050	200	0.2	25~48	1,250	1,200
		250	0.2	25~50	1,250	880	250	0.2	25~48	1,250	1,000
		300	0.2	25~50	950	660	300	0.2	25~48	950	750
		350	0.2	25~28	950	660	350	0.2	25~28	950	750
Hardened die steel (SKD61, DAC, DHA) 42-52HRC	DH102	~150	0.2	25~50	510	360	~150	0.2	25~48	510	410
		200	0.2	25~50	510	360	200	0.2	25~48	510	410
		250	0.2	25~50	510	340	250	0.2	25~48	510	390
		300	0.2	25~50	380	270	300	0.2	25~48	380	310
		350	0.2	25~28	380	270	350	0.2	25~28	380	310
Hardened die steel (SKD11, SLD, DC11) 55-62HRC	DH102	~150	0.2	25~50	380	190	~150	0.2	25~48	380	220
		200	0.2	25~50	380	190	200	0.2	25~48	380	220
		250	0.2	25~50	380	160	250	0.2	25~48	380	180
		300	0.2	25~50	320	130	300	0.2	25~48	320	150
		350	0.2	25~28	320	130	350	0.2	25~28	320	150
Grey & Nodular cast iron (FC, FCD) below 300HB	DH102	~150	0.2	25~50	1,270	1,780	~150	0.2	25~48	1,270	2,030
		200	0.2	25~50	1,270	1,780	200	0.2	25~48	1,270	2,030
		250	0.2	25~50	1,270	1,560	250	0.2	25~48	1,270	1,780
		300	0.2	25~50	950	1,000	300	0.2	25~48	950	1,140
		350	0.2	25~28	950	1,000	350	0.2	25~28	950	1,140
Stainless steel (SUS304) below 250HB	JC8015 (DH102)	~150	0.2	25~50	1,150	1,210	~150	0.2	25~48	1,150	1,380
		200	0.2	25~50	1,150	1,210	200	0.2	25~48	1,150	1,380
		250	0.2	25~50	1,150	1,090	250	0.2	25~48	1,150	1,250
		300	0.2	25~50	830	700	300	0.2	25~48	830	800
		350	0.2	25~28	830	700	350	0.2	25~28	830	800
Titanium alloy (Ti-6Al-4V)	DH102	~150	0.2	25~50	320	340	~150	0.2	25~48	320	390
		200	0.2	25~50	320	340	200	0.2	25~48	320	390
		250	0.2	25~50	320	300	250	0.2	25~48	320	340
		300	0.2	25~50	190	160	300	0.2	25~48	190	180
		350	0.2	25~28	190	160	350	0.2	25~28	190	180

Note

1. Please adjust cutting conditions according to machine rigidity or work rigidity.
2. In case of chatter occurring, recommended to reduce a_p or rpm and keep feed per tooth.
3. a_p should be reduced when using on low rigidity machine.
4. Use air blow.
5. YPHW-F insert with lower feed is recommended for better surface finish in case chatter occurs.
Please scan QR code for cutting conditions of YPHW-F /-24 for bottom finishing.



QM MAX**MQX/QXP Type**

■ Recommended cutting conditions

● QXP Type (YPHW-15 insert) - Bottom finishing

4

Material	Grade	Tool dia.(mm)									
		63/66									
		8N									
		ℓ (mm)	a_p (mm)	a_e (mm)	n (min ⁻¹)	V_f (mm/min)					
Carbon steel (S50C, S55C) below 250HB	CX75 (DH102)	~200	0.2	31~63	1,350	2,700					
		250	0.2	31~63	1,350	2,700					
		300	0.2	31~63	1,350	2,450					
		350	0.2	31~63	1,020	1,630					
		400	0.2	31~35	1,020	1,630					
Tool & die steel (SKD61, SKD11) below 255HB	CX75 (DH102)	~200	0.2	31~63	1,210	2,420					
		250	0.2	31~63	1,210	2,420					
		300	0.2	31~63	1,210	2,190					
		350	0.2	31~63	910	1,450					
		400	0.2	31~35	910	1,450					
Mold steel (HPM7, PX5, P20) 30-36 HRC	DH102	~200	0.2	31~63	1,110	1,750					
		250	0.2	31~63	1,110	1,750					
		300	0.2	31~63	1,110	1,580					
		350	0.2	31~63	830	1,110					
		400	0.2	31~35	830	1,110					
Mold steel (NAK80, HPM1, P21) 38-43HRC	DH102	~200	0.2	31~63	1,000	960					
		250	0.2	31~63	1,000	960					
		300	0.2	31~63	1,000	800					
		350	0.2	31~63	750	590					
		400	0.2	31~35	750	590					
Hardened die steel (SKD61, DAC, DHA) 42-52HRC	DH102	~200	0.2	31~63	400	320					
		250	0.2	31~63	400	320					
		300	0.2	31~63	400	300					
		350	0.2	31~63	300	250					
		400	0.2	31~35	300	250					
Hardened die steel (SKD11, SLD, DC11) 55-62HRC	DH102	~200	0.2	31~63	300	170					
		250	0.2	31~63	300	170					
		300	0.2	31~63	300	140					
		350	0.2	31~63	250	120					
		400	0.2	31~35	250	120					
Grey & Nodular cast iron (FC, FCD) below 300HB	DH102	~200	0.2	31~63	1,000	1,600					
		250	0.2	31~63	1,000	1,600					
		300	0.2	31~63	1,000	1,400					
		350	0.2	31~63	750	900					
		400	0.2	31~35	750	900					
Stainless steel (SUS304) below 250HB	JC8015 (DH102)	~200	0.2	31~63	910	1,090					
		250	0.2	31~63	910	1,090					
		300	0.2	31~63	910	990					
		350	0.2	31~63	660	640					
		400	0.2	31~35	660	640					
Titanium alloy (Ti-6Al-4V)	DH102	~200	0.2	31~63	250	300					
		250	0.2	31~63	250	300					
		300	0.2	31~63	250	270					
		350	0.2	31~63	150	140					
		400	0.2	31~35	150	140					

Note

1. Please adjust cutting conditions according to machine rigidity or work rigidity.
2. In case of chatter occurring, recommended to reduce a_p or rpm and keep feed per tooth.
3. a_p should be reduced when using on low rigidity machine.
4. Use air blow.
5. YPHW-F insert with lower feed is recommended for better surface finish in case chatter occurs.
Please scan QR code for cutting conditions of YPHW-F /-24 for bottom finishing.



QM MAX **MQX/QXP Type**

- Recommended cutting conditions
- MQX Type (YPHW100320ZER-24) - Contour milling

5

Material	Grade	Tool dia.(mm)									
		16/17									
		2N									
		ℓ (mm)	ap (mm)	ae (mm)	n (min ⁻¹)	Vf (mm/min)					
Mold steel (NAK80, HPM1, P21) 38-43HRC	JC8015 (DH102)	~70	0.4	<7	4,400	2,200					
		120	0.3	<7	4,400	2,200					
		160	0.2	<7	4,400	2,200					
Hardened die steel (SKD61, DAC, DHA) 42-52HRC	JC8015 (DH102)	~70	0.25	<7	3,200	1,600					
		120	0.2	<7	3,200	1,600					
		160	-	-	-	-					
Hardened die steel (SKD11, SLD, DC11) 55-62HRC	DH102	~70	0.2	<6	2,000	800					
		120	0.15	<6	2,000	800					
		160	-	-	-	-					

Material	Grade	Tool dia.(mm)									
		20					20/21				
		3N					4N				
		ℓ (mm)	ap (mm)	ae (mm)	n (min ⁻¹)	Vf (mm/min)	ℓ (mm)	ap (mm)	ae (mm)	n (min ⁻¹)	Vf (mm/min)
Mold steel (NAK80, HPM1, P21) 38-43HRC	JC8015 (DH102)	~70	0.4	<9	3,500	2,600	~70	0.4	<9	3,500	3,500
		120	0.3	<9	3,500	2,600	120	0.3	<9	3,500	3,500
		190	0.2	<9	3,500	2,600	190	0.2	<9	3,500	3,500
Hardened die steel (SKD61, DAC, DHA) 42-52HRC	JC8015 (DH102)	~70	0.25	<9	2,550	1,900	~70	0.25	<9	2,550	2,550
		120	0.2	<9	2,550	1,900	120	0.2	<9	2,550	2,550
		190	-	-	-	-	190	-	-	-	-
Hardened die steel (SKD11, SLD, DC11) 55-62HRC	DH102	~70	0.2	<7	1,600	960	~70	0.2	<7	1,600	1,280
		120	0.15	<7	1,600	960	120	0.15	<7	1,600	1,280
		190	-	-	-	-	190	-	-	-	-

- Note
1. Please adjust cutting conditions according to machine rigidity or work rigidity.
 2. In case of chatter occurring, recommended to reduce ap or rpm and keep feed per tooth.
 3. ap should be reduced when using on low rigidity machine.
 4. Use air blow.

QM MAX**MQX/QXP Type**

■ Recommended cutting conditions

● MQX Type (YPHW100320ZER-24) - Contour milling

5

Material	Grade	Tool dia.(mm)									
		25/26					25/26/28				
		4N					5N				
		ℓ (mm)	a_p (mm)	a_e (mm)	n (min ⁻¹)	V_f (mm/min)	ℓ (mm)	a_p (mm)	a_e (mm)	n (min ⁻¹)	V_f (mm/min)
Mold steel (NAK80, HPM1, P21) 38-43HRC	JC8015 (DH102)	~90	0.4	<10	2,800	2,800	~90	0.4	<10	2,800	3,500
		140	0.3	<10	2,800	2,800	140	0.3	<10	2,800	3,500
		210	0.2	<10	2,800	2,800	210	0.2	<10	2,800	3,500
Hardened die steel (SKD61, DAC, DHA) 42-52HRC	JC8015 (DH102)	~90	0.25	<10	2,040	2,040	~90	0.25	<10	2,040	2,550
		140	0.2	<10	2,040	2,040	140	0.2	<10	2,040	2,550
		210	-	-	-	-	210	-	-	-	-
Hardened die steel (SKD11, SLD, DC11) 55-62HRC	DH102	~90	0.2	<8	1,270	1,020	~90	0.2	<8	1,270	1,360
		140	0.15	<8	1,270	1,020	140	0.15	<8	1,270	1,360
		210	-	-	-	-	210	-	-	-	-

Material	Grade	Tool dia.(mm)									
		30/32/35					32/35				
		5N					6N				
		ℓ (mm)	a_p (mm)	a_e (mm)	n (min ⁻¹)	V_f (mm/min)	ℓ (mm)	a_p (mm)	a_e (mm)	n (min ⁻¹)	V_f (mm/min)
Mold steel (NAK80, HPM1, P21) 38-43HRC	JC8015 (DH102)	~100	0.4	<13	2,200	2,750	~100	0.4	<13	2,200	3,300
		150	0.3	<13	2,200	2,750	150	0.3	<13	2,200	3,300
		210	0.2	<13	2,200	2,750	210	0.2	<13	2,200	3,300
Hardened die steel (SKD61, DAC, DHA) 42-52HRC	JC8015 (DH102)	~100	0.25	<13	1,600	2,000	~100	0.25	<13	1,600	2,400
		150	0.2	<13	1,600	2,000	150	0.2	<13	1,600	2,400
		210	0.15	<13	1,600	2,000	210	0.15	<13	1,600	2,400
Hardened die steel (SKD11, SLD, DC11) 55-62HRC	DH102	~100	0.2	<10	1,000	1,000	~100	0.2	<10	1,000	1,200
		150	0.15	<10	1,000	1,000	150	0.15	<10	1,000	1,200
		210	0.1	<10	1,000	1,000	210	0.1	<10	1,000	1,200

Note

1. Please adjust cutting conditions according to machine rigidity or work rigidity.
2. In case of chatter occurring, recommended to reduce a_p or rpm and keep feed per tooth.
3. a_p should be reduced when using on low rigidity machine.
4. Use air blow.

QM MAX**MQX/QXP Type**

■ Recommended cutting conditions

● MQX Type (YPHW100320ZER-24) - Contour milling

5

Material	Grade	Tool dia.(mm)									
		40/42					40				
		6N					7N				
		ℓ (mm)	a_p (mm)	a_e (mm)	n (min ⁻¹)	V_f (mm/min)	ℓ (mm)	a_p (mm)	a_e (mm)	n (min ⁻¹)	V_f (mm/min)
Mold steel (NAK80, HPM1, P21) 38-43HRC	JC8015 (DH102)	~100	0.4	<17	1,750	2,620	~100	0.4	<17	1,750	3,060
		150	0.3	<17	1,750	2,620	150	0.3	<17	1,750	3,060
		210	0.2	<17	1,750	2,620	210	0.2	<17	1,750	3,060
Hardened die steel (SKD61, DAC, DHA) 42-52HRC	JC8015 (DH102)	~100	0.25	<17	1,270	1,900	~100	0.25	<17	1,270	2,220
		150	0.2	<17	1,270	1,900	150	0.2	<17	1,270	2,220
		210	0.15	<17	1,270	1,900	210	0.15	<17	1,270	2,220
Hardened die steel (SKD11, SLD, DC11) 55-62HRC	DH102	~100	0.2	<13	800	960	~100	0.2	<13	800	1,120
		150	0.15	<13	800	960	150	0.15	<13	800	1,120
		210	0.1	<13	800	960	210	0.1	<13	800	1,120

Note

1. Please adjust cutting conditions according to machine rigidity or work rigidity.
2. In case of chatter occurring, recommended to reduce a_p or rpm and keep feed per tooth.
3. a_p should be reduced when using on low rigidity machine.
4. Use air blow.

QM MAX**MQX/QXP Type**

■ Recommended cutting conditions

● QXP Type (YPHW100320ZER-24) - Contour milling

5

Material	Grade	Tool dia.(mm)									
		40									
		6N					7N				
φ (mm)	a_p (mm)	a_e (mm)	n (min ⁻¹)	V_f (mm/min)	φ (mm)	a_p (mm)	a_e (mm)	n (min ⁻¹)	V_f (mm/min)		
Mold steel (NAK80, HPM1, P21) 38-43HRC	JC8015 (DH102)	~100	0.4	<17	1,750	2,620	~100	0.4	<17	1,750	3,060
		150	0.3	<17	1,750	2,620	150	0.3	<17	1,750	3,060
		200	0.2	<17	1,750	2,620	200	0.2	<17	1,750	3,060
		250	0.15	<17	1,750	2,620	250	0.15	<17	1,750	3,060
		300	-	-	-	-	300	-	-	-	-
Hardened die steel (SKD61, DAC, DHA) 42-52HRC	JC8015 (DH102)	~100	0.25	<17	1,270	1,900	~100	0.25	<17	1,270	2,220
		150	0.2	<17	1,270	1,900	150	0.2	<17	1,270	2,220
		200	0.15	<17	1,270	1,900	200	0.15	<17	1,270	2,220
		250	0.1	<17	1,270	1,900	250	0.1	<17	1,270	2,220
		300	-	-	-	-	300	-	-	-	-
Hardened die steel (SKD11, SLD, DC11) 55-62HRC	DH102	~100	0.2	<13	800	960	~100	0.2	<13	800	1,120
		150	0.15	<13	800	960	150	0.15	<13	800	1,120
		200	0.1	<13	800	960	200	0.1	<13	800	1,120
		250	-	-	-	-	250	-	-	-	-
		300	-	-	-	-	300	-	-	-	-

Material	Grade	Tool dia.(mm)									
		50					50/52				
		7N					8N				
φ (mm)	a_p (mm)	a_e (mm)	n (min ⁻¹)	V_f (mm/min)	φ (mm)	a_p (mm)	a_e (mm)	n (min ⁻¹)	V_f (mm/min)		
Mold steel (NAK80, HPM1, P21) 38-43HRC	JC8015 (DH102)	~150	0.4	<21	1,400	2,450	~150	0.4	<21	1,400	2,800
		200	0.3	<21	1,400	2,450	200	0.3	<21	1,400	2,800
		250	0.2	<21	1,400	2,450	250	0.2	<21	1,400	2,800
		300	0.15	<21	1,400	2,450	300	0.15	<21	1,400	2,800
		350	-	-	-	-	350	-	-	-	-
Hardened die steel (SKD61, DAC, DHA) 42-52HRC	JC8015 (DH102)	~150	0.25	<21	1,020	1,780	~150	0.25	<21	1,020	2,040
		200	0.2	<21	1,020	1,780	200	0.2	<21	1,020	2,040
		250	0.15	<21	1,020	1,780	250	0.15	<21	1,020	2,040
		300	0.1	<21	1,020	1,780	300	0.1	<21	1,020	2,040
		350	-	-	-	-	350	-	-	-	-
Hardened die steel (SKD11, SLD, DC11) 55-62HRC	DH102	~150	0.2	<17	640	900	~150	0.2	<17	640	1,030
		200	0.15	<17	640	900	200	0.15	<17	640	1,030
		250	0.1	<17	640	900	250	0.1	<17	640	1,030
		300	-	-	-	-	300	-	-	-	-
		350	-	-	-	-	350	-	-	-	-

Note

1. Please adjust cutting conditions according to machine rigidity or work rigidity.
2. In case of chatter occurring, recommended to reduce a_p or rpm and keep feed per tooth.
3. a_p should be reduced when using on low rigidity machine.
4. Use air blow.

QM MAX**MQX/QXP Type**

■ Recommended cutting conditions

● QXP Type (YPHW100320ZER-24) - Contour milling

5

Material	Grade	Tool dia.(mm)									
		63/66					8N				
		ℓ (mm)	a_p (mm)	a_e (mm)	n (min ⁻¹)	V_f (mm/min)					
Mold steel (NAK80, HPM1, P21) 38-43HRC	JC8015 (DH102)	~150	0.4	<26	1,110	2,220					
		200	0.4	<26	1,110	2,220					
		250	0.3	<26	1,110	2,220					
		300	0.2	<26	1,110	2,220					
		350	0.15	<26	1,110	2,220					
Hardened die steel (SKD61, DAC, DHA) 42-52HRC	JC8015 (DH102)	~150	0.25	<26	810	1,620					
		200	0.25	<26	810	1,620					
		250	0.2	<26	810	1,620					
		300	0.15	<26	810	1,620					
		350	0.1	<26	810	1,620					
Hardened die steel (SKD11, SLD, DC11) 55-62HRC	DH102	~150	0.2	<21	500	800					
		200	0.2	<21	500	800					
		250	0.15	<21	500	800					
		300	0.1	<21	500	800					
		350	-	-	-	-					

Note

1. Please adjust cutting conditions according to machine rigidity or work rigidity.
2. In case of chatter occurring, recommended to reduce a_p or rpm and keep feed per tooth.
3. a_p should be reduced when using on low rigidity machine.
4. Use air blow.

QM MAX**MQX/QXP Type**

■ Recommended cutting conditions

● MQX Type (YPHW-F1 CBN insert) - Side finishing

6

Material	Grade	Tool dia.(mm)									
		16 / 17					20				
		2N					3N				
		l (mm)	a_p (mm)	a_e (mm)	n (min ⁻¹)	V_f (mm/min)	l (mm)	a_p (mm)	a_e (mm)	n (min ⁻¹)	V_f (mm/min)
Hardened die steel (SKD61, DAC, DHA) 42-52HRC	JBN795	~80	≤1.2	<0.1	8,950	1,430	~100	≤1.2	<0.1	7,160	1,720
		120	≤1.0	<0.1	7,960	1,110	150	≤1.0	<0.1	6,370	1,340
		160	-	-	-	-	190	-	-	-	-
Hardened die steel (SKD11, SLD, DC11) 55-62HRC	JBN795	~80	≤1.0	<0.1	7,960	1,270	~100	≤1.0	<0.1	6,370	1,530
		120	≤0.8	<0.1	5,970	720	150	≤0.8	<0.1	4,770	860
		160	-	-	-	-	190	-	-	-	-
Grey cast iron (FC) below 300HB	JBN795	~80	≤1.5	<0.1	14,900	4,020	~100	≤1.5	<0.1	11,900	4,820
		120	≤1.0	<0.1	14,900	3,580	150	≤1.0	<0.1	11,900	4,280
		160	≤0.7	<0.1	14,900	2,980	190	≤0.7	<0.1	11,900	3,570
Nodular cast iron (FCD) below 300HB	JBN795	~80	≤1.5	<0.1	13,900	3,750	~100	≤1.5	<0.1	11,100	4,500
		120	≤1.0	<0.1	13,900	3,340	150	≤1.0	<0.1	11,100	4,000
		160	≤0.7	<0.1	13,900	2,780	190	≤0.7	<0.1	11,100	3,330

Material	Grade	Tool dia.(mm)									
		20 / 21									
		4N									
		l (mm)	a_p (mm)	a_e (mm)	n (min ⁻¹)	V_f (mm/min)					
Hardened die steel (SKD61, DAC, DHA) 42-52HRC	JBN795	~100	≤1.2	<0.1	7,160	2,290					
		150	≤1.0	<0.1	6,370	1,780					
		190	-	-	-	-					
Hardened die steel (SKD11, SLD, DC11) 55-62HRC	JBN795	~100	≤1.0	<0.1	6,370	2,040					
		150	≤0.8	<0.1	4,770	1,140					
		190	-	-	-	-					
Grey cast iron (FC) below 300HB	JBN795	~100	≤1.5	<0.1	11,900	6,430					
		150	≤1.0	<0.1	11,900	5,710					
		190	≤0.7	<0.1	11,900	4,760					
Nodular cast iron (FCD) below 300HB	JBN795	~100	≤1.5	<0.1	11,100	6,000					
		150	≤1.0	<0.1	11,100	5,330					
		190	≤0.7	<0.1	11,100	4,440					

Note

1. Please adjust cutting conditions according to machine rigidity or work rigidity.
2. In case of chatter occurring, recommended to reduce a_p or rpm and keep feed per tooth.
3. a_p should be reduced when using on low rigidity machine.
4. Use air blow.
5. Please scan QR code for cutting conditions of YPHW-F1(CBN)insert for Vertical side finishing or bottom finishing.



QM MAX **MQX/QXP Type**

- Recommended cutting conditions
- MQX Type (YPHW-F1 CBN insert) - Side finishing

6

Material	Grade	Tool dia.(mm)									
		25 / 26					25 / 26 / 28				
		4N					5N				
		ℓ (mm)	a_p (mm)	a_e (mm)	n (min ⁻¹)	V_f (mm/min)	ℓ (mm)	a_p (mm)	a_e (mm)	n (min ⁻¹)	V_f (mm/min)
Hardened die steel (SKD61, DAC, DHA) 42-52HRC	JBN795	~120	≤1.2	<0.1	5,730	1,830	~120	≤1.2	<0.1	5,730	2,290
		190	≤1.0	<0.1	5,090	1,430	190	≤1.0	<0.1	5,090	1,780
		235	-	-	-	-	235	-	-	-	-
Hardened die steel (SKD11, SLD, DC11) 55-62HRC	JBN795	~120	≤1.0	<0.1	5,090	1,630	~120	≤1.0	<0.1	5,090	2,040
		190	≤0.8	<0.1	3,820	920	190	≤0.8	<0.1	3,820	1,150
		235	-	-	-	-	235	-	-	-	-
Grey cast iron (FC) below 300HB	JBN795	~120	≤1.5	<0.1	9,550	5,160	~120	≤1.5	<0.1	9,550	6,450
		190	≤1.0	<0.1	9,550	4,580	190	≤1.0	<0.1	9,550	5,730
		235	≤0.7	<0.1	9,550	3,820	235	≤0.7	<0.1	9,550	4,780
Nodular cast iron (FCD) below 300HB	JBN795	~120	≤1.5	<0.1	8,910	4,810	~120	≤1.5	<0.1	8,910	6,010
		190	≤1.0	<0.1	8,910	4,280	190	≤1.0	<0.1	8,910	5,350
		235	≤0.7	<0.1	8,910	3,560	235	≤0.7	<0.1	8,910	4,460

Material	Grade	Tool dia.(mm)									
		30 / 32 / 35					32 / 35				
		5N					6N				
		ℓ (mm)	a_p (mm)	a_e (mm)	n (min ⁻¹)	V_f (mm/min)	ℓ (mm)	a_p (mm)	a_e (mm)	n (min ⁻¹)	V_f (mm/min)
Hardened die steel (SKD61, DAC, DHA) 42-52HRC	JBN795	~160	≤1.2	<0.1	4,480	1,790	~160	≤1.2	<0.1	4,480	2,150
		240	≤1.0	<0.1	3,980	1,390	240	≤1.0	<0.1	3,980	1,670
		290	-	-	-	-	290	-	-	-	-
Hardened die steel (SKD11, SLD, DC11) 55-62HRC	JBN795	~160	≤1.0	<0.1	3,980	1,590	~160	≤1.0	<0.1	3,980	1,910
		240	≤0.8	<0.1	2,980	900	240	≤0.8	<0.1	2,980	1,070
		290	-	-	-	-	290	-	-	-	-
Grey cast iron (FC) below 300HB	JBN795	~160	≤1.5	<0.1	7,460	5,040	~160	≤1.5	<0.1	7,460	6,040
		240	≤1.0	<0.1	7,460	4,480	240	≤1.0	<0.1	7,460	5,370
		290	≤0.7	<0.1	7,460	3,730	290	≤0.7	<0.1	7,460	4,480
Nodular cast iron (FCD) below 300HB	JBN795	~160	≤1.5	<0.1	6,960	4,700	~160	≤1.5	<0.1	6,960	5,640
		240	≤1.0	<0.1	6,960	4,180	240	≤1.0	<0.1	6,960	5,010
		290	≤0.7	<0.1	6,960	3,480	290	≤0.7	<0.1	6,960	4,180

Note

1. Please adjust cutting conditions according to machine rigidity or work rigidity.
2. In case of chatter occurring, recommended to reduce a_p or rpm and keep feed per tooth.
3. a_p should be reduced when using on low rigidity machine.
4. Use air blow.
5. Please scan QR code for cutting conditions of YPHW-F1(CBN)insert for Vertical side finishing or bottom finishing.



QM MAX**MQX/QXP Type**

■ Recommended cutting conditions

● MQX Type (YPHW-F1 CBN insert) - Side finishing

6

Material	Grade	Tool dia.(mm)									
		40 / 42					40				
		6N					7N				
		l (mm)	a_p (mm)	a_e (mm)	n (min ⁻¹)	V_f (mm/min)	l (mm)	a_p (mm)	a_e (mm)	n (min ⁻¹)	V_f (mm/min)
Hardened die steel (SKD61, DAC, DHA) 42-52HRC	JBN795	~160	≤ 1.2	<0.1	3,580	1,720	~160	≤ 1.2	<0.1	3,580	2,000
		240	≤ 1.0	<0.1	3,180	1,340	240	≤ 1.0	<0.1	3,180	1,560
		290	-	-	-	-	290	-	-	-	-
Hardened die steel (SKD11, SLD, DC11) 55-62HRC	JBN795	~160	≤ 1.0	<0.1	3,180	1,530	~160	≤ 1.0	<0.1	3,180	1,780
		240	≤ 0.8	<0.1	2,390	860	240	≤ 0.8	<0.1	2,390	1,000
		290	-	-	-	-	290	-	-	-	-
Grey cast iron (FC) below 300HB	JBN795	~160	≤ 1.5	<0.1	5,970	4,840	~160	≤ 1.5	<0.1	5,970	5,640
		240	≤ 1.0	<0.1	5,970	4,300	240	≤ 1.0	<0.1	5,970	5,010
		290	≤ 0.7	<0.1	5,970	3,580	290	≤ 0.7	<0.1	5,970	4,180
Nodular cast iron (FCD) below 300HB	JBN795	~160	≤ 1.5	<0.1	5,570	4,510	~160	≤ 1.5	<0.1	5,570	5,260
		240	≤ 1.0	<0.1	5,570	4,010	240	≤ 1.0	<0.1	5,570	4,680
		290	≤ 0.7	<0.1	5,570	3,340	290	≤ 0.7	<0.1	5,570	3,900

Note

1. Please adjust cutting conditions according to machine rigidity or work rigidity.
2. In case of chatter occurring, recommended to reduce a_p or rpm and keep feed per tooth.
3. a_p should be reduced when using on low rigidity machine.
4. Use air blow.
5. Please scan QR code for cutting conditions of YPHW-F1(CBN)insert for Vertical side finishing or bottom finishing.



QM MAX **MQX/QXP Type**

- Recommended cutting conditions
- QXP type (YPHW-F1 CBN insert) - Side finishing

6

Material	Grade	Tool dia.(mm)									
		40					7N				
		ℓ (mm)	ap (mm)	ae (mm)	n (min ⁻¹)	Vf (mm/min)	ℓ (mm)	ap (mm)	ae (mm)	n (min ⁻¹)	Vf (mm/min)
Hardened die steel (SKD61, DAC, DHA) 42-52HRC	JBN795	~150	≤1.2	<0.1	3,580	1,720	~150	≤1.2	<0.1	3,580	2,000
		200	≤1.0	<0.1	3,180	1,340	200	≤1.0	<0.1	3,180	1,560
		250	-	-	-	-	250	-	-	-	-
		300	-	-	-	-	300	-	-	-	-
		350	-	-	-	-	350	-	-	-	-
Hardened die steel (SKD11, SLD, DC11) 55-62HRC	JBN795	~150	≤1.0	<0.1	3,180	1,530	~150	≤1.0	<0.1	3,180	1,780
		200	≤0.8	<0.1	2,390	860	200	≤0.8	<0.1	2,390	1,000
		250	-	-	-	-	250	-	-	-	-
		300	-	-	-	-	300	-	-	-	-
		350	-	-	-	-	350	-	-	-	-
Grey cast iron (FC) below 300HB	JBN795	~150	≤1.5	<0.1	5,970	4,840	~150	≤1.5	<0.1	5,970	5,640
		200	≤1.0	<0.1	5,970	4,300	200	≤1.0	<0.1	5,970	5,010
		250	≤0.7	<0.1	5,970	3,580	250	≤0.7	<0.1	5,970	4,180
		300	≤0.7	<0.1	5,970	3,580	300	≤0.7	<0.1	5,970	4,180
		350	-	-	-	-	350	-	-	-	-
Nodular cast iron (FCD) below 300HB	JBN795	~150	≤1.5	<0.1	5,570	4,510	~150	≤1.5	<0.1	5,570	5,260
		200	≤1.0	<0.1	5,570	4,010	200	≤1.0	<0.1	5,570	4,680
		250	≤0.7	<0.1	5,570	3,340	250	≤0.7	<0.1	5,570	3,900
		300	≤0.7	<0.1	5,570	3,340	300	≤0.7	<0.1	5,570	3,900
		350	-	-	-	-	350	-	-	-	-

Material	Grade	Tool dia.(mm)									
		50					50/52				
		ℓ (mm)	ap (mm)	ae (mm)	n (min ⁻¹)	Vf (mm/min)	ℓ (mm)	ap (mm)	ae (mm)	n (min ⁻¹)	Vf (mm/min)
Hardened die steel (SKD61, DAC, DHA) 42-52HRC	JBN795	~150	≤1.2	<0.1	2,860	1,600	~150	≤1.2	<0.1	2,860	1,830
		200	≤1.2	<0.1	2,860	1,600	200	≤1.2	<0.1	2,860	1,830
		250	≤1.0	<0.1	2,550	1,250	250	≤1.0	<0.1	2,550	1,430
		300	≤1.0	<0.1	2,550	1,250	300	≤1.0	<0.1	2,550	1,430
		350	-	-	-	-	350	-	-	-	-
Hardened die steel (SKD11, SLD, DC11) 55-62HRC	JBN795	~150	≤1.0	<0.1	2,550	1,430	~150	≤1.0	<0.1	2,550	1,630
		200	≤1.0	<0.1	2,550	1,430	200	≤1.0	<0.1	2,550	1,630
		250	≤0.8	<0.1	1,910	800	250	≤0.8	<0.1	1,910	920
		300	≤0.8	<0.1	1,910	800	300	≤0.8	<0.1	1,910	920
		350	-	-	-	-	350	-	-	-	-
Grey cast iron (FC) below 300HB	JBN795	~150	≤1.5	<0.1	4,780	4,520	~150	≤1.5	<0.1	4,780	5,160
		200	≤1.5	<0.1	4,780	4,520	200	≤1.5	<0.1	4,780	5,160
		250	≤1.0	<0.1	4,780	4,020	250	≤1.0	<0.1	4,780	4,590
		300	≤1.0	<0.1	4,780	4,020	300	≤1.0	<0.1	4,780	4,590
		350	≤0.7	<0.1	4,780	3,350	350	≤0.7	<0.1	4,780	3,820
Nodular cast iron (FCD) below 300HB	JBN795	~150	≤1.5	<0.1	4,460	4,210	~150	≤1.5	<0.1	4,460	4,820
		200	≤1.5	<0.1	4,460	4,210	200	≤1.5	<0.1	4,460	4,820
		250	≤1.0	<0.1	4,460	3,750	250	≤1.0	<0.1	4,460	4,280
		300	≤1.0	<0.1	4,460	3,750	300	≤1.0	<0.1	4,460	4,280
		350	≤0.7	<0.1	4,460	3,120	350	≤0.7	<0.1	4,460	3,570

Note

1. Please adjust cutting conditions according to machine rigidity or work rigidity.
2. In case of chatter occurring, recommended to reduce ap or rpm and keep feed per tooth.
3. ap should be reduced when using on low rigidity machine.
4. Use air blow.
5. Please scan QR code for cutting conditions of YPHW-F1(CBN)insert for Vertical side finishing or bottom finishing.



QM MAX**MQX/QXP Type**

■ Recommended cutting conditions

● QXP type (YPHW-F1 CBN insert) - Side finishing

6

Material	Grade	Tool dia.(mm)									
		63/66					8N				
		l (mm)	a_p (mm)	a_e (mm)	n (min ⁻¹)	V_f (mm/min)					
Hardened die steel (SKD61, DAC, DHA) 42-52HRC	JBN795	~200	≤1.2	<0.1	2,270	1,450					
		250	≤1.2	<0.1	2,270	1,450					
		300	≤1.0	<0.1	2,020	1,130					
		350	≤1.0	<0.1	2,020	1,130					
		400	-	-	-	-					
Hardened die steel (SKD11, SLD, DC11) 55-62HRC	JBN795	~200	≤1.0	<0.1	2,020	1,290					
		250	≤1.0	<0.1	2,020	1,290					
		300	≤0.8	<0.1	1,520	730					
		350	≤0.8	<0.1	1,520	730					
		400	-	-	-	-					
Grey cast iron (FC) below 300HB	JBN795	~200	≤1.5	<0.1	3,790	4,090					
		250	≤1.5	<0.1	3,790	4,090					
		300	≤1.0	<0.1	3,790	3,640					
		350	≤1.0	<0.1	3,790	3,640					
		400	≤0.7	<0.1	3,790	3,030					
Nodular cast iron (FCD) below 300HB	JBN795	~200	≤1.5	<0.1	3,540	3,820					
		250	≤1.5	<0.1	3,540	3,820					
		300	≤1.0	<0.1	3,540	3,400					
		350	≤1.0	<0.1	3,540	3,400					
		400	≤0.7	<0.1	3,540	2,830					

Note

1. Please adjust cutting conditions according to machine rigidity or work rigidity.
2. In case of chatter occurring, recommended to reduce a_p or rpm and keep feed per tooth.
3. a_p should be reduced when using on low rigidity machine.
4. Use air blow.
5. Please scan QR code for cutting conditions of YPHW-F1(CBN)insert for Vertical side finishing or bottom finishing.



QM MILL **MPM/PME Type**



Low cutting force geometry

- Unique 3D geometry insert provides stable cutting and less power consumption.
- BT30 Capable of running on low horse power & compact machines.

Multi - flutes specification

High speed and high efficient machining.

Vibration free

Control vibration with combination of MSN carbide shank holder for longer tool life.

Low cutting force geometry High feed machining with Multi-flutes specification

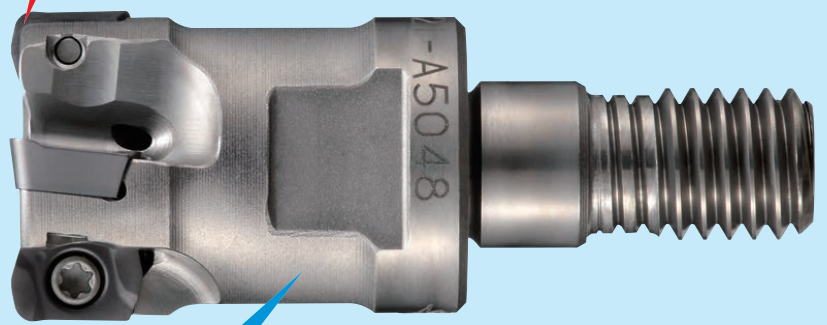

Adopted G-Body Possible to use even for finishing applications

Insert Line-Up

A variety of inserts all fit into the same body.

High feed insert



EOMT0602...ZER (R1.0, 2.0)

High feed insert for unfavorable conditions

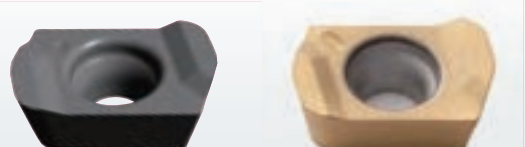

EOMW060210ZER

Shoulder insert



ZOMT0602...ZER-PL (R0.2,0.4,0.8)

For high hardened steel



EOHW0602...ZTR (R1.0, 2.0)

"Mirror Insert"
for finishing side & bottom face



YOHW0602...ZER-12

QM MILL **MPM/PME Type**

■ Endmill Shank Type



■ PME type (Through coolant hole)

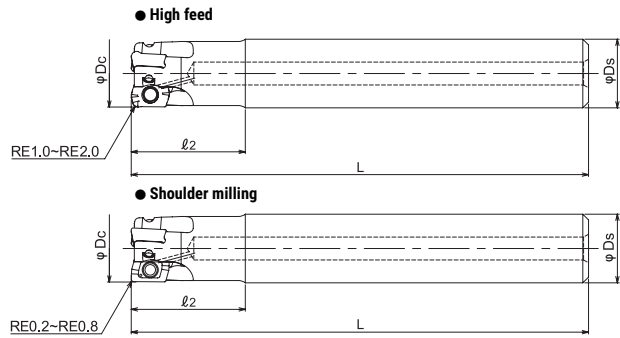

■ PME-LS type (No coolant hole)

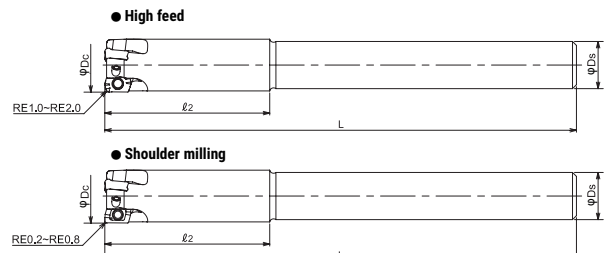

Type	Cat.No.	Stock	No. of inserts	Dimensions (mm)					Inserts	
				φDc	ℓ2	L	φD1	φDs		
Standard	PME2010S10	●	2	10	20	80	9.3	10	EO**0602**Z*R; ZOMT0602**ZER; YOHW0602**ZER-12	
	PME3012S12	●	3	12			10.3	12		
	PME3014S12	●		14			11.2			
Long shank	PME2011S10-LS	●	2	11	33	120	12.2	10		
	PME3013S12-LS	●	3	13			39	13.15		12
	PME3014S12-LS	●		14			42			

Screw	Torque(N.m)	Wrench
DSW-1840H	0.4	A-06

QM MILL **MPM/PME Type**

■ **Modular Head Type**

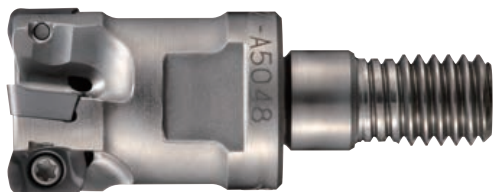
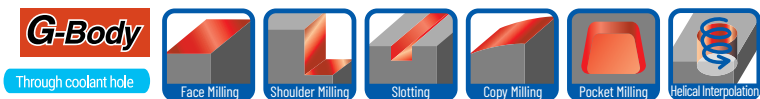

● **High feed**

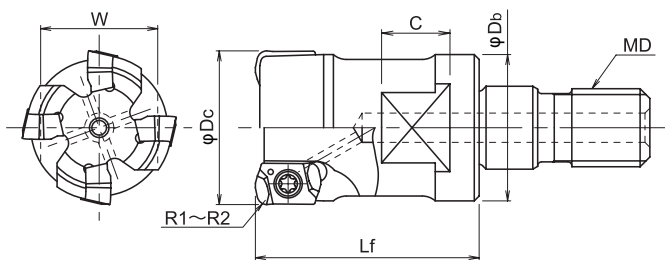

● **Shoulder milling**

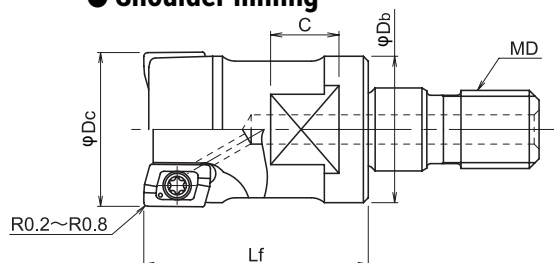

Cat.No.	Stock	No. of inserts	Dimensions (mm)						Inserts
			φDc	Lf	φDb	MD	C	W	
MPM-2010-M6	●	2	10	18	9.5	M6	6.5	8	EO**0602**Z*R; ZOMT0602**ZER; YOHWO602**ZER-12
MPM-2011-M6	●		11		9.7	M6			
MPM-3012-M6	●	3	12	20	11.2	M6			
MPM-3013-M6	●		13		11.5	M6			
MPM-3015-M8	●	4	15	23	14	M8	8	12	
MPM-4016-M8	●		16		15	M8			
MPM-4017-M8	●		17			M8			
MPM-4018-M8	●		18			M8			
MPM-5020-M10	●	5	20	30	19	M10	9	14	
MPM-5021-M10	●		21			M10			
MPM-6025-M12	●	6	25	35	23.6	M12	10	17	
MPM-7030-M16	●	7	30	43	29	M16	12	22	
MPM-8032-M16	●					8			

Screw	Torque(N.m)	Wrench
DSW-1840H	0.4	A-06

QM MILL **MPM/PME Type**

■ **Insert**

High feed insert

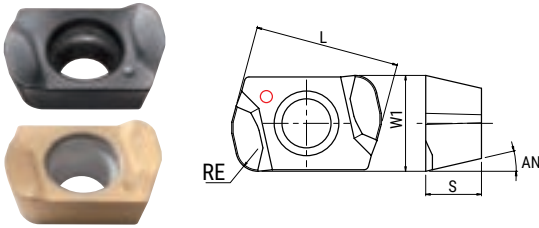

For high hardened steel

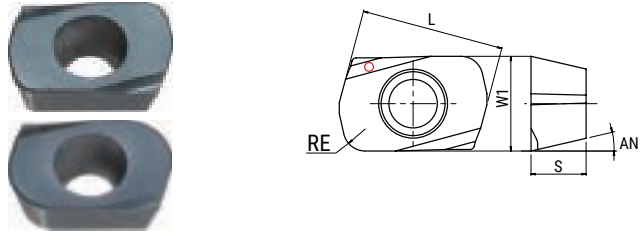

High feed insert for unfavorable conditions

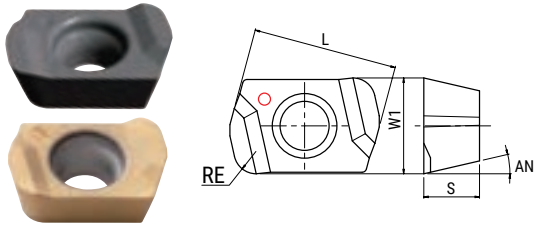

Shoulder insert

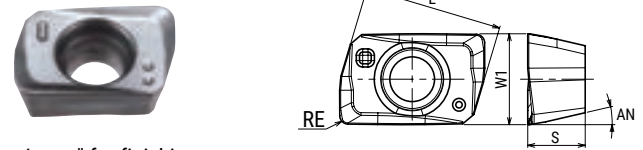

"Mirror Insert" for finishing side & bottom face

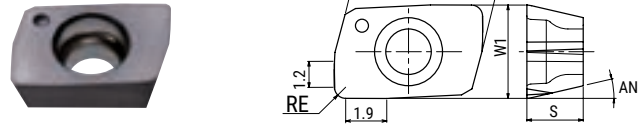

Type	Cat.No.	Tolerance	PVD Coating						Dimensions (mm)				
			DH102	DS118	DS150	JC7560	JC8015	JC8050	JC8118	RE	L	W1	S
High feed insert	EOMT060210ZER	M		●	●	●		●	●	1	6.5	2.5	13°
	EOMT060220ZER			●	●			●	●	2			
High feed insert for unfavorable conditions	EOMW060210ZER					●		●	●	1			
For high hardened steel	EOHW060210ZTR	H	●						●				
	EOHW060220ZTR		●						●	2			
shoulder insert	ZOMT060202ZER-PL	M						●	●	0.2	6.62	4.3	2.7
	ZOMT060204ZER-PL							●	●	0.4			
	ZOMT060208ZER-PL							●	●	0.8			
"Mirror Insert" for finishing side & bottom face	YOHW060203ZER-12	H	●							0.3	6.5	2.6	13°
	YOHW060205ZER-12		●							0.5			
	YOHW060208ZER-12		●							0.8			

GRADE MARKINGS

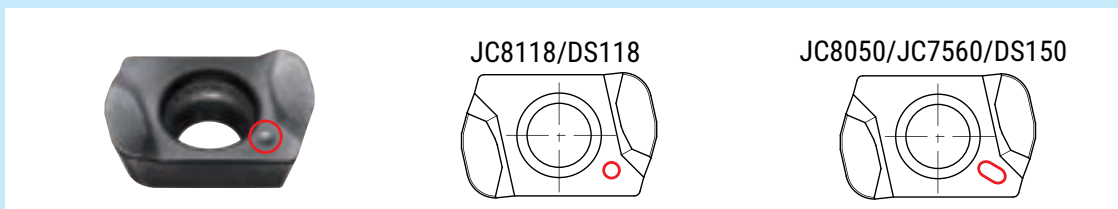

■ **MAGNETIZER**



- Magnetizing and demagnetizing a wrench can easily be done by inserting the tip into the magnetizer and rubbing lightly.
- Do not use in the vicinity of the equipment that can be influenced with magnetism.

Cat.No.	Stock
MAGNETISER	●

QM MILL **MPM/PME Type**

■ Insert selection guide

Material	Carbon steel (S50C, S55C) below 250HB						Tool & die steel # (SKD61, SKD11) below 255HB						
	Cat.No. \ Grade	JC8118	JC8050	JC7560	DH102	DS118	DS150	JC8118	JC8050	JC7560	DH102	DS118	DS150
EOMT0602*0ZER	☆	☆	☆				☆	☆	☆				
EOMW060210ZER	○	○	◎				○	○	◎				
EOHW0602*0ZTR													

Material	Mold steel (HPM7, PX5, KPM30) 30-36HRC						Mold steel (NAK80, HPM1) 38-43HRC						
	Cat.No. \ Grade	JC8118	JC8050	JC7560	DH102	DS118	DS150	JC8118	JC8050	JC7560	DH102	DS118	DS150
EOMT0602*0ZER	☆	☆	☆				☆	☆					
EOMW060210ZER	○	○	◎				◎	○					
EOHW0602*0ZTR													

Material	Hardened die steel (SKD61, DAC, DHA) 42-52HRC						Hardened die steel (SKD11, SLD, DC11) 55-62HRC						
	Cat.No. \ Grade	JC8118	JC8050	JC7560	DH102	DS118	DS150	JC8118	JC8050	JC7560	DH102	DS118	DS150
EOMT0602*0ZER	☆						x	x					
EOMW060210ZER	○	●					○						
EOHW0602*0ZTR	◎						●			◎			

Material	Cast iron (FC, FCD) below 300HB						Stainless steel (SUS304) below 250HB						
	Cat.No. \ Grade	JC8118	JC8050	JC7560	DH102	DS118	DS150	JC8118	JC8050	JC7560	DH102	DS118	DS150
EOMT0602*0ZER	○							◎	○				
EOMW060210ZER	◎		●					●					
EOHW0602*0ZTR													

Material	Titanium alloy (Ti-6Al-4V)						Heat resistant alloy (INCO718)						
	Cat.No. \ Grade	JC8118	JC8050	JC7560	DH102	DS118	DS150	JC8118	JC8050	JC7560	DH102	DS118	DS150
EOMT0602*0ZER	○	○	◎		○	◎	◎	○	○			○	○
EOMW060210ZER			●					●					
EOHW0602*0ZTR													

◎: First choice ○: For general milling ●: For unstable milling ☆: For light cutting force x: Not recommended

QM MILL **MPM/PME Type**

■ Definition of corner shape for programming

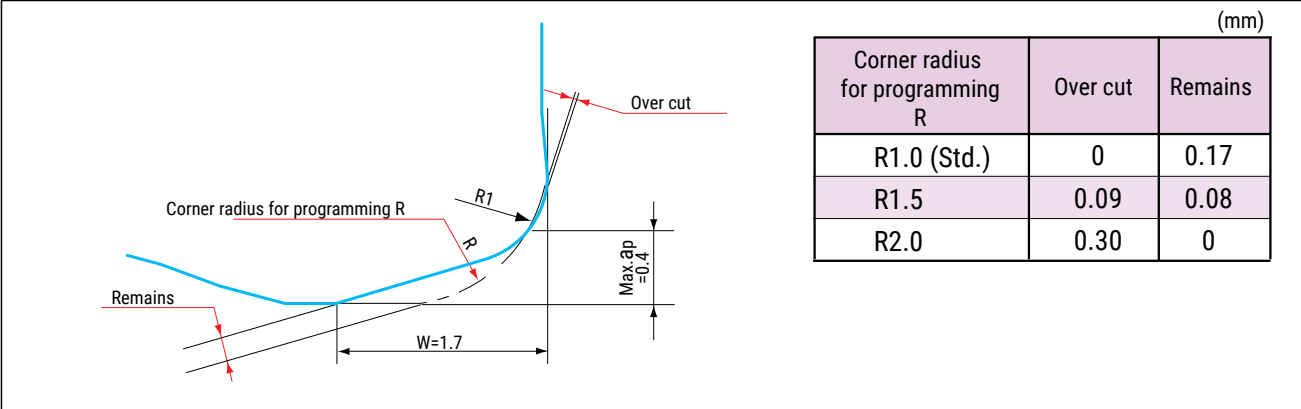

■ Recommended Data for Profile Milling

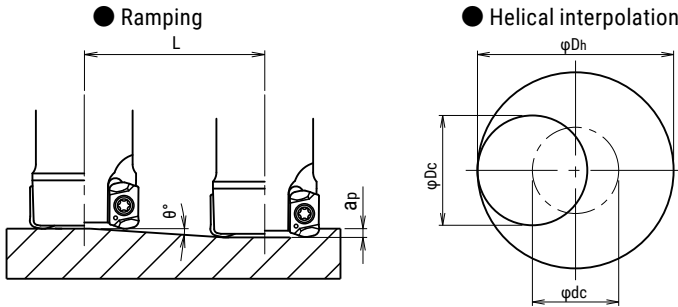

- Calculation of tool pass dia.
 $\varphi_{dc} = \varphi_{Dh} - \varphi_{Dc}$
 Tool pass dia. Bore dia. Tool Dia.
- Depth of cut per one circuit should not exceed max. depth of cut A_p
- Down cutting is recommended, tool pass rotation should be counterclockwise

- In case of ramping and helical interpolation, apply 70% or less feed (V_f) from standard cutting condition table
- In case of drilling, apply 50% or less Z axis feed (F) from standard cutting condition table
- Long consecutive chips may result in case of drilling, confirm safe operating conditions

Cat.No.	Tool dia. (mm)	Effective cutting dia. (mm)	Max.depth of cut: A_p (mm)	Ramping		Helical interpolation	
				Max. ramping angle θ	Max. depth of cut (A_p) Total cutting length L(mm)	Min. Bore dia. (mm)	Max. Bore dia. (mm)
MPM-2010-M6	10	6.6	0.3	2°18'	7.5	15	18
MPM-2011-M6	11	7.6	0.3	1°54'	9	17	20
MPM-3012-M6	12	8.5	0.3	1°36'	10.7	19	22
MPM-3013-M6	13	9.5	0.3	1°24'	12.3	21	24
MPM-3015-M8	15	11.5	0.4	1°12'	19.1	25	28
MPM-4016-M8	16	12.5	0.4	1°	22.9	27	30
MPM-4017-M8	17	13.5	0.4	0°54'	25.5	29	32
MPM-4018-M8	18	14.5	0.4	0°51'	27.0	31	34
MPM-5020-M10	20	16.5	0.4	0°45'	30.6	35	38
MPM-5021-M10	21	17.5	0.4	0°42'	32.7	37	40
MPM-6025-M12	25	21.5	0.4	0°30'	45.8	45	48
MPM-7030-M16	30	26.5	0.4	0°27'	50.9	55	58
MPM-8032-M16	32	28.5	0.4	0°24'	57.3	59	62
PME2010S10	10	6.6	0.3	2°18'	7.5	15	18
PME2011S10-LS	11	7.6	0.3	1°54'	9	17	20
PME3012S12	12	8.5	0.3	1°36'	10.7	19	22
PME3013S12-LS	13	9.5	0.3	1°24'	12.3	21	24
PME3014S12 (-LS)	14	10.5	0.3	1°18'	13.2	23	26

QM MILL **MPM Type**

■ Recommended cutting conditions

● MPM type (EOMT/W insert)

1

Material	Grade	Tool dia.(mm)														
		10/11					12/13/14/15					16/17/18				
		2N					3N					4N				
		ℓ (mm)	ap (mm)	ae (mm)	n (min ⁻¹)	Vf (mm/min)	ℓ (mm)	ap (mm)	ae (mm)	n (min ⁻¹)	Vf (mm/min)	ℓ (mm)	ap (mm)	ae (mm)	n (min ⁻¹)	Vf (mm/min)
Carbon steel (S50C, S55C) below 250HB	JC7560 (JC8050) (JC8118)	50	0.3	~6	3,820	4,580	60	0.3	~8	3,180	5,720	70	0.4	~12	2,390	8,600
		75	0.25	~6	3,440	3,720	80	0.25	~8	2,860	4,630	120	0.3	~12	2,150	6,970
		100	0.2	~5	3,060	2,940	110	0.2	~7	2,540	3,660	160	0.25	~12	1,910	5,500
Tool & die steel (SKD61, SKD11) below 255HB	JC7560 (JC8050) (JC8118)	50	0.3	~6	3,500	4,200	60	0.3	~8	2,920	5,260	70	0.4	~12	2,190	7,880
		75	0.2	~6	3,150	3,400	80	0.2	~8	2,630	4,260	120	0.3	~12	1,970	6,380
		100	0.15	~5	2,800	2,690	110	0.15	~7	2,340	3,370	160	0.25	~12	1,750	4,900
Mold steel (HPM7, PX5, P20) 30-36 HRC	JC8118 (JC7560) (JC8050)	50	0.3	~6	3,500	4,200	60	0.3	~8	2,920	5,260	70	0.4	~12	2,190	7,880
		75	0.25	~6	3,150	3,400	80	0.25	~8	2,630	4,260	120	0.3	~12	1,970	6,380
		100	0.2	~5	2,800	2,690	110	0.2	~7	2,340	3,370	160	0.25	~12	1,750	4,900
Mold steel (NAK80, HPM1, P21) 38-43HRC	JC8118 (JC8050)	50	0.3	~6	2,860	3,150	60	0.3	~8	2,390	3,940	70	0.3	~12	1,790	5,010
		75	0.25	~6	2,570	2,540	80	0.25	~8	2,150	3,190	120	0.25	~12	1,610	4,060
		100	0.2	~5	2,290	2,010	110	0.2	~7	1,910	2,520	160	0.2	~12	1,430	3,200
Hardened die steel (SKD61, DAC, DHA) 42-52HRC	JC8118 (JC8050)	50	0.25	~6	2,230	2,230	60	0.25	~8	1,860	2,790	70	0.3	~12	1,390	3,340
		75	0.15	~6	2,010	1,810	80	0.15	~8	1,670	2,250	120	0.2	~12	1,250	2,700
		100	-	-	-	-	110	-	-	-	-	160	-	-	-	-
Hardened die steel (SKD11, SL, DC11) 55-62HRC	JC8118 EOMW Type	50	0.1	~6	950	470	60	0.1	~8	800	600	70	0.15	~12	600	600
		75	-	-	-	-	80	-	-	-	-	120	0.1	~12	540	490
		100	-	-	-	-	110	-	-	-	-	160	-	-	-	-
Grey & Nodular cast iron (FC, FCD) below 300HB	JC8118 (JC7560)	50	0.3	~6	4,780	5,740	60	0.3	~8	3,980	7,160	70	0.4	~12	2,980	10,730
		75	0.25	~6	4,300	4,640	80	0.25	~8	3,580	5,800	120	0.35	~12	2,680	8,680
		100	0.2	~6	3,820	3,670	110	0.2	~8	3,180	4,580	160	0.3	~12	2,380	6,850
Stainless steel (SUS304) below 250HB	JC8050 (JC7560)	50	0.3	~6	3,820	4,580	60	0.3	~8	3,180	5,720	70	0.4	~12	2,390	8,600
		75	0.2	~6	3,440	3,720	80	0.2	~8	2,860	4,630	120	0.3	~12	2,150	6,880
		100	0.15	~5	3,060	2,940	110	0.15	~7	2,540	3,660	160	0.25	~12	1,910	5,350
Titanium alloy (Ti-6Al-4V)	JC7560 DS150 (JC8118) (DS118) (JC8050)	50	0.3	~6	1,910	1,910	60	0.3	~8	1,590	2,380	70	0.3	~12	1,190	2,380
		75	0.2	~6	1,720	1,550	80	0.2	~8	1,430	1,930	120	0.25	~12	1,070	1,930
		100	0.15	~5	1,530	1,220	110	0.15	~7	1,270	1,520	160	0.2	~12	950	1,520
Heat resistant alloy (INCO718)	JC8118 DS118 (JC7560) (DS150) (JC8050)	50	0.3	~6	950	760	60	0.3	~8	800	960	70	0.3	~12	600	960
		75	0.2	~6	850	760	80	0.2	~8	720	780	120	0.25	~12	540	780
		100	0.15	~5	760	610	110	0.15	~7	640	610	160	0.2	~12	480	610

Note

1. Please adjust cutting conditions according to machine rigidity or work rigidity.
2. In case of chatter occurring, recommended to reduce ap or rpm and keep feed per tooth.
3. ap should be reduced when using on low rigidity machine.
4. Use air blow.

QM MILL**MPM Type**

■ Recommended cutting conditions

● MPM type (EOMT/W insert)

1

Material	Grade	Tool dia.(mm)									
		20/21					25				
		5N					6N				
		ℓ (mm)	a_p (mm)	a_e (mm)	n (min ⁻¹)	V_f (mm/min)	ℓ (mm)	a_p (mm)	a_e (mm)	n (min ⁻¹)	V_f (mm/min)
Carbon steel (S50C, S55C) below 250HB	JC7560	70	0.4	~14	1,910	8,600	90	0.4	~18	1,530	8,260
	(JC8050)	120	0.3	~14	1,720	6,970	140	0.3	~18	1,380	6,710
	(JC8118)	190	0.25	~14	1,530	5,510	210	0.25	~18	1,220	5,270
Tool & die steel (SKD61, SKD11) below 255HB	JC7560	70	0.4	~14	1,750	7,880	90	0.4	~18	1,400	7,560
	(JC8050)	120	0.3	~14	1,580	6,400	140	0.3	~18	1,260	6,120
	(JC8118)	190	0.25	~14	1,400	5,040	210	0.25	~18	1,120	4,840
Mold steel (HPM7, PX5, P20) 30-36 HRC	JC8118	70	0.4	~14	1,750	7,880	90	0.4	~18	1,400	7,560
	(JC7560)	120	0.3	~14	1,580	6,400	140	0.3	~18	1,260	6,120
	(JC8050)	190	0.25	~14	1,400	5,040	210	0.25	~18	1,120	4,840
Mold steel (NAK80, HPM1, P21) 38-43HRC	JC8118	70	0.3	~14	1,430	5,000	90	0.3	~18	1,150	4,830
	(JC8050)	120	0.25	~14	1,290	4,060	140	0.25	~18	1,040	3,930
		190	0.2	~14	1,140	3,190	210	0.2	~18	920	3,090
Hardened die steel (SKD61, DAC, DHA) 42-52HRC	JC8118	70	0.3	~14	1,110	3,330	90	0.3	~18	890	3,200
	(JC8050)	120	0.2	~14	1,000	2,700	140	0.2	~18	800	2,590
		190	-	-	-	-	210	-	-	-	-
Hardened die steel (SKD11, SLD, DC11) 55-62HRC	JC8118	70	0.15	~14	480	600	90	0.15	~18	380	570
	EOMW	120	0.1	~14	430	480	140	0.1	~18	340	460
	Type	190	-	-	-	-	210	-	-	-	-
Grey & Nodular cast iron (FC, FCD) below 300HB	JC8118	70	0.4	~14	2,390	10,750	90	0.4	~18	1,910	10,310
	(JC7560)	120	0.35	~14	2,150	8,710	140	0.35	~18	1,720	8,360
		190	0.3	~14	1,910	6,880	210	0.3	~18	1,530	6,610
Stainless steel (SUS304) below 250HB	JC8050	70	0.4	~14	1,910	8,600	90	0.4	~18	1,530	8,260
	(JC7560)	120	0.3	~14	1,720	6,970	140	0.3	~18	1,380	6,710
		190	0.25	~14	1,530	5,510	210	0.25	~18	1,220	5,270
Titanium alloy (Ti-6Al-4V)	JC7560	70	0.3	~14	950	2,380	90	0.3	~18	760	2,280
	DS150	120	0.25	~14	860	1,940	140	0.25	~18	680	1,840
	(JC8118) (DS118) (JC8050)	190	0.2	~14	760	1,520	210	0.2	~18	610	1,460
Heat resistant alloy (INCO718)	JC8118	70	0.3	~14	480	960	90	0.3	~18	380	910
	DS118	120	0.25	~14	430	860	140	0.25	~18	340	730
	(JC7560) (DS150) (JC8050)	190	0.2	~14	380	610	210	0.2	~18	300	580

Note

1. Please adjust cutting conditions according to machine rigidity or work rigidity.
2. In case of chatter occurring, recommended to reduce a_p or rpm and keep feed per tooth.
3. a_p should be reduced when using on low rigidity machine.
4. Use air blow.

QM MILL **MPM Type**

- Recommended cutting conditions
- MPM type (EOMT/W insert)

1

Material	Grade	Tool dia.(mm)									
		30					32				
		7N					8N				
		ℓ (mm)	ap (mm)	ae (mm)	n (min ⁻¹)	Vf (mm/min)	ℓ (mm)	ap (mm)	ae (mm)	n (min ⁻¹)	Vf (mm/min)
Carbon steel (S50C, S55C) below 250HB	JC7560 (JC8050) (JC8118)	100	0.4	~22	1,270	8,000	100	0.4	~24	1,190	8,570
		150	0.3	~22	1,140	6,460	150	0.3	~24	1,070	6,930
		210	0.25	~22	1,020	5,140	210	0.25	~24	950	5,470
Tool & die steel (SKD61, SKD11) below 255HB	JC7560 (JC8050) (JC8118)	100	0.4	~22	1,170	7,370	100	0.4	~24	1,090	7,850
		150	0.3	~22	1,050	5,950	150	0.3	~24	980	6,350
		210	0.25	~22	940	5,330	210	0.25	~24	870	5,010
Mold steel (HPM7, PX5, P20) 30-36 HRC	JC8118 (JC7560) (JC8050)	100	0.4	~22	1,170	7,370	100	0.4	~24	1,090	7,850
		150	0.3	~22	1,050	5,950	150	0.3	~24	980	6,350
		210	0.25	~22	940	5,330	210	0.25	~24	870	5,010
Mold steel (NAK80, HPM1, P21) 38-43HRC	JC8118 (JC8050)	100	0.3	~22	950	4,660	100	0.3	~24	900	5,040
		150	0.25	~22	860	3,790	150	0.25	~24	810	4,080
		210	0.2	~22	760	2,980	210	0.2	~24	720	3,220
Hardened die steel (SKD61, DAC, DHA) 42-52HRC	JC8118 (JC8050)	100	0.3	~22	740	3,110	100	0.3	~24	700	3,360
		150	0.2	~22	670	2,530	150	0.2	~24	600	2,590
		210	0.15	~22	590	1,980	210	0.15	~24	500	1,920
Hardened die steel (SKD11, SL, DC11) 55-62HRC	EOMW Type	100	0.15	~22	320	560	100	0.15	~24	300	600
		150	0.1	~22	290	460	150	0.1	~24	270	490
		210	-	-	-	-	210	-	-	-	-
Grey & Nodular cast iron (FC, FCD) below 300HB	JC8118 (JC7560)	100	0.4	~22	1,590	10,000	100	0.4	~24	1,490	10,730
		150	0.35	~22	1,430	8,110	150	0.35	~24	1,340	8,680
		210	0.3	~22	1,270	6,400	210	0.3	~24	1,190	6,850
Stainless steel (SUS304) below 250HB	JC8050 (JC7560)	100	0.4	~22	1,270	8,000	100	0.4	~24	1,190	8,570
		150	0.3	~22	1,140	6,460	150	0.3	~24	1,070	6,930
		210	0.25	~22	1,020	5,140	210	0.25	~24	950	5,470
Titanium alloy (Ti-6Al-4V)	JC7560 DS150 (JC8118) (DS118) (JC8050)	100	0.3	~22	640	2,240	100	0.3	~24	600	2,400
		150	0.25	~22	580	1,830	150	0.25	~24	540	1,940
		210	0.2	~22	510	1,430	210	0.2	~24	480	1,540
Heat resistant alloy (INCO718)	JC8118 DS118 (JC7560) (DS150) (JC8050)	100	0.3	~22	320	900	100	0.3	~24	300	960
		150	0.25	~22	290	730	150	0.25	~24	270	780
		210	0.2	~22	260	580	210	0.2	~24	240	610

Note

1. Please adjust cutting conditions according to machine rigidity or work rigidity.
2. In case of chatter occurring, recommended to reduce ap or rpm and keep feed per tooth.
3. ap should be reduced when using on low rigidity machine.
4. Use air blow.

QM MILL**MPM Type**

■ Recommended cutting conditions

● MPM type (EOMT/W insert)

②

Material	Grade	Tool dia.(mm)														
		10/11					12/13/14/15					16/17/18				
		2N					3N					4N				
		ℓ (mm)	a _p (mm)	a _e (mm)	n (min ⁻¹)	V _f (mm/min)	ℓ (mm)	a _p (mm)	a _e (mm)	n (min ⁻¹)	V _f (mm/min)	ℓ (mm)	a _p (mm)	a _e (mm)	n (min ⁻¹)	V _f (mm/min)
Hardened die steel (SKD61, DAC, DHA) 42-52HRC	JC8118	40	0.20	~6	2,860	2,860	50	0.20	~7	2,390	3,590	65	0.25	~12	1,790	4,300
		60	0.15	~6	2,570	2,060	70	0.15	~7	2,150	2,580	95	0.20	~12	1,610	3,090
		80	0.10	~6	2,290	1,370	95	0.10	~7	1,910	1,720	125	0.10	~12	1,430	2,060
Hardened die steel (SKD11, SLD, DC11) 55-62HRC	DH102	40	0.15	~6	2,550	1,530	50	0.15	~7	2,120	1,900	65	0.15	~12	1,590	1,900
		60	0.10	~6	2,300	1,240	70	0.10	~7	1,910	1,550	95	0.10	~12	1,430	1,520
		80	-	-	-	-	95	-	-	-	-	125	-	-	-	-

Note

1. Please adjust cutting conditions according to machine rigidity or work rigidity.
2. In case of chatter occurring, recommended to reduce a_p or rpm and keep feed per tooth.
3. a_p should be reduced when using on low rigidity machine.
4. Use air blow.

QM MILL**MPM Type**

■ Recommended cutting conditions

● MPM type (EOMT/W insert)

2

Material	Grade	Tool dia.(mm)									
		20/21					25				
		5N					6N				
		ℓ (mm)	a_p (mm)	a_e (mm)	n (min ⁻¹)	V_f (mm/min)	ℓ (mm)	a_p (mm)	a_e (mm)	n (min ⁻¹)	V_f (mm/min)
Hardened die steel (SKD61, DAC, DHA) 42-52HRC	JC8118	80	0.25	~14	1,430	4,290	100	0.25	~18	1,150	4,140
		120	0.2	~14	1,290	3,100	150	0.2	~18	1,040	3,000
		160	0.10	~14	1,140	2,050	200	0.10	~18	920	1,990
Hardened die steel (SKD11, SLD, DC11) 55-62HRC	DH102	80	0.15	~14	1,270	1,900	100	0.15	~18	1,020	1,840
		120	0.1	~14	1,140	1,540	150	0.1	~18	920	1,490
		160	-	-	-	-	200	-	-	-	-

Material	Grade	Tool dia.(mm)									
		30					32				
		7N					8N				
		ℓ (mm)	a_p (mm)	a_e (mm)	n (min ⁻¹)	V_f (mm/min)	ℓ (mm)	a_p (mm)	a_e (mm)	n (min ⁻¹)	V_f (mm/min)
Hardened die steel (SKD61, DAC, DHA) 42-52HRC	JC8118	120	0.25	~22	950	3,990	120	0.25	~24	900	4,320
		180	0.20	~22	860	2,890	180	0.20	~24	810	3,110
		240	0.10	~22	760	1,920	240	0.10	~24	720	2,070
Hardened die steel (SKD11, SLD, DC11) 55-62HRC	DH102	120	0.15	~22	850	1,780	120	0.15	~24	800	1,920
		180	0.10	~22	760	1,430	180	0.10	~24	720	1,560
		240	-	-	-	-	240	-	-	-	-

Note

1. Please adjust cutting conditions according to machine rigidity or work rigidity.
2. In case of chatter occurring, recommended to reduce a_p or rpm and keep feed per tooth.
3. a_p should be reduced when using on low rigidity machine.
4. Use air blow.

QM MILL**MPM Type**

■ Recommended cutting conditions

● MPM type (ZOMT insert)

3

Material	Chipbreaker	Grade	Tool dia.(mm)														
			10/11					12/13/15					16/17/18				
			2N					3N					4N				
			ℓ (mm)	a _p (mm)	a _p ×a _e (mm ²)	n (min ⁻¹)	V _f (mm/min)	ℓ (mm)	a _p (mm)	a _p ×a _e (mm ²)	n (min ⁻¹)	V _f (mm/min)	ℓ (mm)	a _p (mm)	a _p ×a _e (mm ²)	n (min ⁻¹)	V _f (mm/min)
Carbon steel (S50C, S55C) below 250HB	PL	JC8050 (JC8118)	50	~4.0	~6.0	5,090	810	60	~4.0	~8.0	4,240	1,020	70	~5.0	~10.0	3,180	1,020
			75	~1.2	~1.8	4,580	640	80	~1.7	~2.6	3,820	800	120	~2.0	~3.0	2,860	800
			100	~0.5	~0.8	4,070	490	110	~0.6	~1.2	3,400	610	160	~0.7	~1.3	2,550	610
Tool & die steel (SKD61, SKD11) below 255HB	PL	JC8050 (JC8118)	50	~4.0	~6.0	4,770	570	60	~4.0	~8.0	3,980	720	70	~5.0	~10.0	2,980	720
			75	~1.2	~1.8	4,300	430	80	~1.7	~2.6	3,580	540	120	~2.0	~3.0	2,690	540
			100	~0.5	~0.8	3,820	310	110	~0.6	~1.2	3,180	380	160	~0.7	~1.3	2,390	380
Mold steel (HPM7, PX5, P20) 30-36 HRC	PL	JC8118 (JC8050)	50	~4.0	~6.0	4,770	480	60	~4.0	~8.0	3,980	600	70	~5.0	~10.0	2,980	600
			75	~1.2	~1.8	4,300	340	80	~1.7	~2.6	3,580	430	120	~2.0	~3.0	2,690	430
			100	~0.5	~0.8	3,820	230	110	~0.6	~1.2	3,180	290	160	~0.7	~1.3	2,390	290
Mold steel (NAK80, HPM1, P21) 38-43HRC	PL	JC8118 (JC8050)	50	~3.0	~4.0	3,820	380	60	~3.0	~4.5	3,180	480	70	~4.0	~6.0	2,390	480
			75	~1.2	~1.6	3,440	280	80	~1.3	~1.8	2,860	340	120	~1.7	~2.2	2,150	340
			100	~0.5	~0.8	3,060	180	110	~0.6	~1.0	2,550	230	160	~0.6	~1.1	1,910	230
Hardened die steel (SKD61, DAC, DHA) 42-52HRC	PL	JC8118	50	~2.5	~3.0	3,180	320	60	~2.5	~3.5	2,650	400	70	~3.5	~5.5	1,990	400
			75	~1.0	~1.4	2,860	230	80	~1.0	~1.5	2,390	290	120	~1.4	~2.0	1,790	290
			100	~0.5	~0.6	2,550	150	110	~0.5	~0.8	2,120	190	160	~0.5	~1.0	1,590	190
Grey & Nodular cast iron (FC, FCD) below 300HB	PL	JC8118	50	~4.0	~6.0	4,770	760	60	~4.0	~8.0	3,980	960	70	~5.0	~10.0	2,980	950
			75	~1.2	~1.8	4,300	600	80	~1.7	~2.6	3,580	750	120	~2.0	~3.0	2,690	750
			100	~0.5	~0.8	3,820	460	110	~0.6	~1.2	3,180	570	160	~0.7	~1.3	2,390	570
Stainless steel (SUS304) below 250HB	PL	JC8050	50	~4.0	~6.0	4,770	570	60	~4.0	~8.0	3,980	720	70	~5.0	~10.0	2,980	720
			75	~1.2	~1.8	4,300	430	80	~1.7	~2.6	3,580	540	120	~2.0	~3.0	2,690	540
			100	~0.5	~0.8	3,820	310	110	~0.6	~1.2	3,180	380	160	~0.7	~1.3	2,390	380

Note

1. Please adjust cutting conditions according to machine rigidity or work rigidity.
2. In case of chatter occurring, recommended to reduce a_p or rpm and keep feed per tooth.
3. a_p should be reduced when using on low rigidity machine.
4. Use air blow.
5. Please scan QR code for cutting conditions of ZOMT insert for side finishing or bottom finishing.



QM MILL**MPM Type**

■ Recommended cutting conditions

● MPM type (ZOMT insert)

3

Material	Chipbreaker	Grade	Tool dia.(mm)									
			20/21					25				
			5N					6N				
			ℓ (mm)	ap (mm)	ap×ae (mm ²)	n (min ⁻¹)	Vf (mm/min)	ℓ (mm)	ap (mm)	ap×ae (mm ²)	n (min ⁻¹)	Vf (mm/min)
Carbon steel (S50C, S55C) below 250HB	PL	JC8050 (JC8118)	70	~5.0	~16.0	2,550	1,020	90	~5.0	~20.0	2,040	980
			120	~4.0	~8.0	2,290	800	140	~4.0	~10.0	1,830	770
			190	~3.0	~4.0	2,040	610	210	~3.0	~8.0	1,630	590
Tool & die steel (SKD61, SKD11) below 255HB	PL	JC8050 (JC8118)	70	~5.0	~16.0	2,390	720	90	~5.0	~20.0	1,910	690
			120	~4.0	~8.0	2,150	540	140	~4.0	~10.0	1,720	520
			190	~3.0	~4.0	1,910	380	210	~3.0	~8.0	1,530	370
Mold steel (HPM7, PX5, P20) 30-36 HRC	PL	JC8118 (JC8050)	70	~5.0	~16.0	2,390	600	90	~5.0	~20.0	1,910	570
			120	~4.0	~8.0	2,150	430	140	~4.0	~10.0	1,720	410
			190	~3.0	~4.0	1,910	290	210	~3.0	~8.0	1,530	280
Mold steel (NAK80, HPM1, P21) 38-43HRC	PL	JC8118 (JC8050)	70	~4.0	~16.0	1,910	480	90	~4.0	~20.0	1,530	460
			120	~3.0	~8.0	1,720	340	140	~3.0	~10.0	1,380	330
			190	~2.0	~4.0	1,530	230	210	~2.0	~8.0	1,220	220
Hardened die steel (SKD61, DAC, DHA) 42-52HRC	PL	JC8118	70	~3.5	~10.0	1,590	400	90	~3.5	~12.5	1,270	380
			120	~2.5	~5.0	1,430	290	140	~2.5	~6.2	1,150	280
			190	~1.2	~2.5	1,270	190	210	~1.2	~3.2	1,020	180
Grey & Nodular Cast iron (FC, FCD) below 300HB	PL	JC8118	70	~5.0	~18.0	2,390	960	90	~5.0	~25.0	1,910	920
			120	~4.0	~10.0	2,150	750	140	~4.0	~12.0	1,720	720
			190	~3.0	~5.0	1,910	570	210	~3.0	~9.0	1,530	550
Stainless steel (SUS304) below 250HB	PL	JC8050	70	~5.0	~16.0	2,390	720	90	~5.0	~20.0	1,910	690
			120	~4.0	~8.0	2,150	540	140	~4.0	~10.0	1,720	520
			190	~3.0	~4.0	1,910	380	210	~3.0	~8.0	1,530	370

Note

1. Please adjust cutting conditions according to machine rigidity or work rigidity.
2. In case of chatter occurring, recommended to reduce ap or rpm and keep feed per tooth.
3. ap should be reduced when using on low rigidity machine.
4. Use air blow.
5. Please scan QR code for cutting conditions of ZOMT insert for side finishing or bottom finishing.



QM MILL**MPM Type**

■ Recommended cutting conditions

● MPM type (ZOMT insert)

3

Material	Chipbreaker	Grade	Tool dia.(mm)									
			30					32				
			7N					8N				
			l (mm)	a_p (mm)	$a_p \times a_e$ (mm ²)	n (min ⁻¹)	V_f (mm/min)	l (mm)	a_p (mm)	$a_p \times a_e$ (mm ²)	n (min ⁻¹)	V_f (mm/min)
Carbon steel (S50C, S55C) below 250HB	PL	JC8050 (JC8118)	100	~5.0	~22.0	1,700	950	100	~5.0	~22.0	1,590	1,020
			150	~4.0	~15.0	1,530	750	150	~4.0	~15.0	1,430	800
			210	~3.0	~8.0	1,360	570	210	~3.0	~8.0	1,270	610
Tool & die steel (SKD61, SKD11) below 255HB	PL	JC8050 (JC8118)	100	~5.0	~22.0	1,590	670	100	~5.0	~22.0	1,490	720
			150	~4.0	~15.0	1,430	500	150	~4.0	~15.0	1,340	540
			210	~3.0	~8.0	1,270	360	210	~3.0	~8.0	1,190	380
Mold steel (HPM7, PX5, P20) 30-36 HRC	PL	JC8118 (JC8050)	100	~5.0	~22.0	1,590	560	100	~5.0	~22.0	1,490	600
			150	~4.0	~15.0	1,430	400	150	~4.0	~15.0	1,340	430
			210	~3.0	~8.0	1,270	270	210	~3.0	~8.0	1,190	290
Mold steel (NAK80, HPM1, P21) 38-43HRC	PL	JC8118 (JC8050)	100	~5.0	~22.0	1,270	440	100	~5.0	~22.0	1,190	480
			150	~4.0	~15.0	1,150	320	150	~4.0	~15.0	1,070	340
			210	~3.0	~8.0	1,020	210	210	~3.0	~8.0	950	230
Hardened die steel (SKD61, DAC, DHA) 42-52HRC	PL	JC8118	100	~4.0	~15.0	1,060	370	100	~4.0	~15.0	990	400
			150	~3.0	~7.5	950	270	150	~3.0	~7.5	900	290
			210	~2.0	~3.8	850	180	210	~2.0	~3.8	800	190
Grey & Nodular cast iron (FC, FCD) below 300HB	PL	JC8118	100	~5.0	~24.0	1,590	890	100	~5.0	~24.0	1,490	950
			150	~4.0	~16.0	1,430	700	150	~4.0	~16.0	1,340	750
			210	~3.0	~9.0	1,270	530	210	~3.0	~9.0	1,190	570
Stainless steel (SUS304) below 250HB	PL	JC8050	100	~5.0	~22.0	1,590	670	100	~5.0	~22.0	1,490	720
			150	~4.0	~15.0	1,430	500	150	~4.0	~15.0	1,340	540
			210	~3.0	~8.0	1,270	360	210	~3.0	~8.0	1,190	380

Note

1. Please adjust cutting conditions according to machine rigidity or work rigidity.
2. In case of chatter occurring, recommended to reduce a_p or rpm and keep feed per tooth.
3. a_p should be reduced when using on low rigidity machine.
4. Use air blow.
5. Please scan QR code for cutting conditions of ZOMT insert for side finishing or bottom finishing.



QM MILL**MPM Type**

■ Recommended cutting conditions

● MPM type (YOHV insert) - Side finishing

4

Material	Grade	Tool dia.(mm)									
		10/11					12/13/14/15				
		2N					3N				
		ℓ (mm)	a _p (mm)	a _e (mm)	n (min ⁻¹)	V _f (mm/min)	ℓ (mm)	a _p (mm)	a _e (mm)	n (min ⁻¹)	V _f (mm/min)
Carbon steel (S50C, S55C) below 250HB	JC8015 (DH102)	~50	≤1.2	≤0.10	12,600	3,780	~60	≤1.2	≤0.10	10,600	4,770
		75	≤0.8	≤0.08	8,820	2,120	80	≤0.8	≤0.08	7,420	2,670
		100	≤0.6	≤0.08	8,820	1,760	110	≤0.6	≤0.08	7,420	2,230
Tool & die steel (SKD61, SKD11) below 255HB	JC8015 (DH102)	~50	≤1.0	≤0.10	11,400	3,420	~60	≤1.0	≤0.10	9,550	4,300
		75	≤0.7	≤0.08	7,980	1,920	80	≤0.7	≤0.08	6,690	2,400
		100	≤0.5	≤0.08	7,980	1,600	110	≤0.5	≤0.08	6,690	2,000
Mold steel (HPM7, PX5, P20) 30-36 HRC	JC8015 (DH102)	~50	≤1.0	≤0.10	11,400	3,420	~60	≤1.0	≤0.10	9,550	4,300
		75	≤0.7	≤0.08	7,980	1,920	80	≤0.7	≤0.08	6,690	2,400
		100	≤0.5	≤0.08	7,980	1,600	110	≤0.5	≤0.08	6,690	2,000
Mold steel (NAK80, HPM1, P21) 38-43HRC	DH102 (JC8015)	~50	≤1.0	≤0.10	8,880	2,130	~60	≤1.0	≤0.10	7,430	2,670
		75	≤0.7	≤0.08	6,180	1,240	80	≤0.7	≤0.08	5,200	1,560
		100	≤0.5	≤0.08	6,180	990	110	≤0.5	≤0.08	5,200	1,250
Hardened die steel (SKD61, DAC, DHA) 42-52HRC	DH102 (JC8015)	~50	≤0.8	≤0.10	6,360	1,270	~60	≤0.8	≤0.10	5,300	1,590
		75	≤0.5	≤0.08	4,440	710	80	≤0.5	≤0.08	3,710	890
		100	—	—	—	—	110	—	—	—	—
Hardened die steel (SKD11, SLD, DC11) 55-62HRC	DH102	~50	≤0.5	≤0.10	4,740	950	~60	≤0.5	≤0.10	3,980	1,190
		75	≤0.3	≤0.08	3,300	530	80	≤0.3	≤0.08	2,790	670
		100	—	—	—	—	110	—	—	—	—
Grey & Nodular cast iron (FC, FCD) below 300HB	JC8015 (DH102)	~50	≤1.2	≤0.12	12,600	3,780	~60	≤1.2	≤0.12	10,600	4,770
		75	≤0.8	≤0.10	8,820	2,120	80	≤0.8	≤0.10	7,420	2,670
		100	≤0.6	≤0.08	8,820	1,760	110	≤0.6	≤0.08	7,420	2,230
Stainless steel (SUS304) below 250HB	JC8015 (DH102)	~50	≤1.0	≤0.10	11,400	3,420	~60	≤1.0	≤0.10	9,550	4,300
		75	≤0.7	≤0.08	7,980	1,920	80	≤0.7	≤0.08	6,690	2,400
		100	≤0.5	≤0.08	7,980	1,600	110	≤0.5	≤0.08	6,690	2,000
Titanium alloy (Ti-6Al-4V)	JC8015 (DH102)	~50	≤1.0	≤0.10	2,520	600	~60	≤1.0	≤0.10	2,120	760
		75	≤0.7	≤0.08	1,740	350	80	≤0.7	≤0.08	1,480	450
		100	≤0.5	≤0.08	1,740	280	110	≤0.5	≤0.08	1,480	360

Note

1. Please adjust cutting conditions according to machine rigidity or work rigidity.
2. In case of chatter occurring, recommended to reduce a_p or rpm and keep feed per tooth.
3. a_p should be reduced when using on low rigidity machine.
4. Use air blow.

QM MILL**MPM Type**

■ Recommended cutting conditions

● MPM type (YOHW insert) - Side finishing

4

Material	Grade	Tool dia.(mm)									
		16/17/18					20/21				
		4N					5N				
		ℓ (mm)	a_p (mm)	a_e (mm)	n (min ⁻¹)	V_f (mm/min)	ℓ (mm)	a_p (mm)	a_e (mm)	n (min ⁻¹)	V_f (mm/min)
Carbon steel (S50C, S55C) below 250HB	JC8015 (DH102)	~80	≤1.2	≤0.10	7,960	4,770	~100	≤1.2	≤0.10	6,300	4,770
		120	≤0.8	≤0.08	5,560	2,670	150	≤0.8	≤0.08	4,410	2,670
		160	≤0.6	≤0.08	5,560	2,230	190	≤0.6	≤0.08	4,410	2,230
Tool & die steel (SKD61, SKD11) below 255HB	JC8015 (DH102)	~80	≤1.0	≤0.10	7,160	4,300	~100	≤1.0	≤0.10	5,700	4,300
		120	≤0.7	≤0.08	5,000	2,400	150	≤0.7	≤0.08	3,990	2,400
		160	≤0.5	≤0.08	5,000	2,000	190	≤0.5	≤0.08	3,990	2,000
Mold steel (HPM7, PX5, P20) 30-36 HRC	JC8015 (DH102)	~80	≤1.0	≤0.10	7,160	4,300	~100	≤1.0	≤0.10	5,700	4,300
		120	≤0.7	≤0.08	5,000	2,400	150	≤0.7	≤0.08	3,990	2,400
		160	≤0.5	≤0.08	5,000	2,000	190	≤0.5	≤0.08	3,990	2,000
Mold steel (NAK80, HPM1, P21) 38-43HRC	DH102 (JC8015)	~80	≤1.0	≤0.10	5,560	2,670	~100	≤1.0	≤0.10	4,440	2,670
		120	≤0.7	≤0.08	3,900	1,560	150	≤0.7	≤0.08	3,090	1,560
		160	≤0.5	≤0.08	3,900	1,250	190	≤0.5	≤0.08	3,090	1,250
Hardened die steel (SKD61, DAC, DHA) 42-52HRC	DH102 (JC8015)	~80	≤0.8	≤0.10	3,980	1,590	~100	≤0.8	≤0.10	3,180	1,590
		120	≤0.5	≤0.08	2,780	890	150	≤0.5	≤0.08	2,220	890
		160	—	—	—	—	190	—	—	—	—
Hardened die steel (SKD11, SLD, DC11) 55-62HRC	DH102	~80	≤0.5	≤0.10	2,980	1,190	~100	≤0.5	≤0.10	2,370	1,190
		120	≤0.3	≤0.08	2,080	670	150	≤0.3	≤0.08	1,650	670
		160	—	—	—	—	190	—	—	—	—
Grey & Nodular cast iron (FC, FCD) below 300HB	JC8015 (DH102)	~80	≤1.2	≤0.12	7,960	4,770	~100	≤1.2	≤0.12	6,300	4,770
		120	≤0.8	≤0.10	5,560	2,670	150	≤0.8	≤0.10	4,410	2,670
		160	≤0.6	≤0.08	5,560	2,230	190	≤0.6	≤0.08	4,410	2,230
Stainless steel (SUS304) below 250HB	JC8015 (DH102)	~80	≤1.0	≤0.10	7,160	4,300	~100	≤1.0	≤0.10	5,700	4,300
		120	≤0.7	≤0.08	5,000	2,400	150	≤0.7	≤0.08	3,990	2,400
		160	≤0.5	≤0.08	5,000	2,000	190	≤0.5	≤0.08	3,990	2,000
Titanium alloy (Ti-6Al-4V)	JC8015 (DH102)	~80	≤1.0	≤0.10	1,600	760	~100	≤1.0	≤0.10	1,260	760
		120	≤0.7	≤0.08	1,120	450	150	≤0.7	≤0.08	870	450
		160	≤0.5	≤0.08	1,120	360	190	≤0.5	≤0.08	870	360

Note

1. Please adjust cutting conditions according to machine rigidity or work rigidity.
2. In case of chatter occurring, recommended to reduce a_p or rpm and keep feed per tooth.
3. a_p should be reduced when using on low rigidity machine.
4. Use air blow.

QM MILL**MPM Type**

■ Recommended cutting conditions

● MPM type (YOHW insert) - Side finishing

4

Material	Grade	Tool dia.(mm)														
		25					30					32				
		6N					7N					8N				
		ℓ (mm)	a _p (mm)	a _e (mm)	n (min ⁻¹)	V _f (mm/min)	ℓ (mm)	a _p (mm)	a _e (mm)	n (min ⁻¹)	V _f (mm/min)	ℓ (mm)	a _p (mm)	a _e (mm)	n (min ⁻¹)	V _f (mm/min)
Carbon steel (S50C, S55C) below 250HB	JC8015 (DH102)	~120	≤1.2	≤0.10	5,090	4,580	~160	≤1.2	≤0.10	4,200	4,410	~160	≤1.2	≤0.10	3,980	4,770
		190	≤0.8	≤0.08	3,560	2,560	240	≤0.8	≤0.08	2,940	2,470	240	≤0.8	≤0.08	2,780	2,670
		235	≤0.6	≤0.08	3,560	2,140	290	≤0.6	≤0.08	2,940	2,060	290	≤0.6	≤0.08	2,780	2,230
Tool & die steel (SKD61, SKD11) below 255HB	JC8015 (DH102)	~120	≤1.0	≤0.10	4,580	4,120	~160	≤1.0	≤0.10	3,800	3,990	~160	≤1.0	≤0.10	3,580	4,300
		190	≤0.7	≤0.08	3,200	2,300	240	≤0.7	≤0.08	2,660	2,230	240	≤0.7	≤0.08	2,500	2,400
		235	≤0.5	≤0.08	3,200	1,920	290	≤0.5	≤0.08	2,660	1,860	290	≤0.5	≤0.08	2,500	2,000
Mold steel (HPM7, PX5, P20) 30-36 HRC	JC8015 (DH102)	~120	≤1.0	≤0.10	4,580	4,120	~160	≤1.0	≤0.10	3,800	3,990	~160	≤1.0	≤0.10	3,580	4,300
		190	≤0.7	≤0.08	3,200	2,300	240	≤0.7	≤0.08	2,660	2,230	240	≤0.7	≤0.08	2,500	2,400
		235	≤0.5	≤0.08	3,200	1,920	290	≤0.5	≤0.08	2,660	1,860	290	≤0.5	≤0.08	2,500	2,000
Mold steel (NAK80, HPM1, P21) 38-43HRC	DH102 (JC8015)	~120	≤1.0	≤0.10	3,560	2,560	~160	≤1.0	≤0.10	2,960	2,490	~160	≤1.0	≤0.10	2,780	2,670
		190	≤0.7	≤0.08	2,490	1,490	240	≤0.7	≤0.08	2,060	1,440	240	≤0.7	≤0.08	1,950	1,560
		235	≤0.5	≤0.08	2,490	1,200	290	≤0.5	≤0.08	2,060	1,150	290	≤0.5	≤0.08	1,950	1,250
Hardened die steel (SKD61, DAC, DHA) 42-52HRC	DH102 (JC8015)	~120	≤0.8	≤0.10	2,550	1,530	~160	≤0.8	≤0.10	2,120	1,480	~160	≤0.8	≤0.10	1,990	1,590
		190	≤0.5	≤0.08	1,780	850	240	≤0.5	≤0.08	1,480	830	240	≤0.5	≤0.08	1,390	890
		235	—	—	—	—	290	—	—	—	—	290	—	—	—	—
Hardened die steel (SKD11, SLD, DC11) 55-62HRC	DH102	~120	≤0.5	≤0.10	1,910	1,150	~160	≤0.5	≤0.10	1,580	1,110	~160	≤0.5	≤0.10	1,490	1,190
		190	≤0.3	≤0.08	1,340	640	240	≤0.3	≤0.08	1,100	620	240	≤0.3	≤0.08	1,040	670
		235	—	—	—	—	290	—	—	—	—	290	—	—	—	—
Gery & Nodular cast iron (FC, FCD) below 300HB	JC8015 (DH102)	~120	≤1.2	≤0.12	5,090	4,580	~160	≤1.2	≤0.12	4,200	4,410	~160	≤1.2	≤0.12	3,980	4,770
		190	≤0.8	≤0.10	3,560	2,560	240	≤0.8	≤0.10	2,940	2,470	240	≤0.8	≤0.10	2,780	2,670
		235	≤0.6	≤0.08	3,560	2,140	290	≤0.6	≤0.08	2,940	2,060	290	≤0.6	≤0.08	2,780	2,230
Stainless steel (SUS304) below 250HB	JC8015 (DH102)	~120	≤1.0	≤0.10	4,580	4,120	~160	≤1.0	≤0.10	3,800	3,990	~160	≤1.0	≤0.10	3,580	4,300
		190	≤0.7	≤0.08	3,200	2,300	240	≤0.7	≤0.08	2,660	2,230	240	≤0.7	≤0.08	2,500	2,400
		235	≤0.5	≤0.08	3,200	1,920	290	≤0.5	≤0.08	2,660	1,860	290	≤0.5	≤0.08	2,500	2,000
Titanium alloy (Ti-6Al-4V)	JC8015 (DH102)	~120	≤1.0	≤0.10	1,020	730	~160	≤1.0	≤0.10	840	710	~160	≤1.0	≤0.10	800	760
		190	≤0.7	≤0.08	710	430	240	≤0.7	≤0.08	580	410	240	≤0.7	≤0.08	560	450
		235	≤0.5	≤0.08	710	340	290	≤0.5	≤0.08	580	320	290	≤0.5	≤0.08	560	360

Note

1. Please adjust cutting conditions according to machine rigidity or work rigidity.
2. In case of chatter occurring, recommended to reduce ap or rpm and keep feed per tooth.
3. ap should be reduced when using on low rigidity machine.
4. Use air blow.

QM MILL**MPM Type**

■ Recommended cutting conditions

● MPM type (YOHW insert) - Bottom finishing

4

Material	Grade	Tool dia.(mm)									
		10/11					12/13/14/15				
		2N					3N				
		ℓ (mm)	a _p (mm)	a _e (mm)	n (min ⁻¹)	V _f (mm/min)	ℓ (mm)	a _p (mm)	a _e (mm)	n (min ⁻¹)	V _f (mm/min)
Carbon steel (S50C, S55C) below 250HB	JC8015 (DH102)	~50	≤0.12	5~10	7,920	3,170	~60	≤0.12	6~12	6,630	3,980
		75	≤0.10	5~10	5,940	1,900	80	≤0.10	6~12	4,970	2,380
		100	≤0.10	5~8	5,100	1,430	110	≤0.10	6~10	4,300	1,800
Tool & die steel (SKD61, SKD11) below 255HB	JC8015 (DH102)	~50	≤0.12	5~10	7,320	2,640	~60	≤0.12	6~12	6,100	3,290
		75	≤0.10	5~10	5,460	1,580	80	≤0.10	6~12	4,580	1,980
		100	≤0.10	5~8	4,740	1,190	110	≤0.10	6~10	3,960	1,500
Mold steel (HPM7, PX5, P20) 30-36 HRC	JC8015 (DH102)	~50	≤0.12	5~10	7,320	2,640	~60	≤0.12	6~12	6,100	3,290
		75	≤0.10	5~10	5,460	1,580	80	≤0.10	6~12	4,580	1,980
		100	≤0.10	5~8	4,740	1,190	110	≤0.10	6~10	3,960	1,500
Mold steel (NAK80, HPM1, P21) 38-43HRC	DH102 (JC8015)	~50	≤0.12	5~10	6,360	1,530	~60	≤0.12	6~12	5,300	1,910
		75	≤0.10	5~10	4,800	920	80	≤0.10	6~12	3,980	1,150
		100	≤0.10	5~8	4,140	700	110	≤0.10	6~10	3,450	870
Hardened die steel (SKD61, DAC, DHA) 42-52HRC	DH102 (JC8015)	~50	≤0.10	5~10	3,840	770	~60	≤0.10	6~12	3,180	960
		75	≤0.08	5~10	2,880	460	80	≤0.08	6~12	2,380	570
		100	—	—	—	—	110	—	—	—	—
Hardened die steel (SKD11, SLD, DC11) 55-62HRC	DH102	~50	≤0.10	5~10	2,220	350	~60	≤0.10	6~12	1,860	450
		75	≤0.08	5~10	1,680	210	80	≤0.08	6~12	1,400	270
		100	—	—	—	—	110	—	—	—	—
Grey & Nodular cast iron (FC, FCD) below 300HB	JC8015 (DH102)	~50	≤0.15	5~10	6,360	1,910	~60	≤0.15	6~12	5,300	2,380
		75	≤0.12	5~10	4,800	1,150	80	≤0.12	6~12	3,980	1,430
		100	≤0.10	5~8	4,140	810	110	≤0.10	6~10	3,450	1,010
Stainless steel (SUS304) below 250HB	JC8015 (DH102)	~50	≤0.12	5~10	7,320	2,640	~60	≤0.12	6~12	6,100	3,290
		75	≤0.10	5~10	5,460	1,580	80	≤0.10	6~12	4,580	1,980
		100	≤0.10	5~8	4,740	1,190	110	≤0.10	6~10	3,960	1,500
Titanium alloy (Ti-6Al-4V)	JC8015 (DH102)	~50	≤0.12	5~10	1,560	370	~60	≤0.12	6~12	1,330	480
		75	≤0.10	5~10	1,200	230	80	≤0.10	6~12	1,000	290
		100	≤0.10	5~8	1,020	170	110	≤0.10	6~10	860	220

Note

1. Please adjust cutting conditions according to machine rigidity or work rigidity.
2. In case of chatter occurring, recommended to reduce a_p or rpm and keep feed per tooth.
3. a_p should be reduced when using on low rigidity machine.
4. Use air blow.

QM MILL**MPM Type**

■ Recommended cutting conditions

● MPM type (YOHW insert) - Bottom finishing

4

Material	Grade	Tool dia.(mm)									
		16/17/18					20/21				
		4N					5N				
		ℓ (mm)	a _p (mm)	a _e (mm)	n (min ⁻¹)	V _f (mm/min)	ℓ (mm)	a _p (mm)	a _e (mm)	n (min ⁻¹)	V _f (mm/min)
Carbon steel (S50C, S55C) below 250HB	JC8015 (DH102)	~80	≦0.12	8~16	4,980	3,980	~100	≦0.12	10~20	3,960	3,980
		120	≦0.10	8~16	3,740	2,380	150	≦0.10	10~20	2,970	2,380
		160	≦0.10	8~13	3,240	1,800	190	≦0.10	10~16	2,550	1,800
Tool & die steel (SKD61, SKD11) below 255HB	JC8015 (DH102)	~80	≦0.12	8~16	4,580	3,290	~100	≦0.12	10~20	3,660	3,290
		120	≦0.10	8~16	3,440	1,980	150	≦0.10	10~20	2,730	1,980
		160	≦0.10	8~13	2,980	1,500	190	≦0.10	10~16	2,370	1,500
Mold steel (HPM7, PX5, P20) 30-36 HRC	JC8015 (DH102)	~80	≦0.12	8~16	4,580	3,290	~100	≦0.12	10~20	3,660	3,290
		120	≦0.10	8~16	3,440	1,980	150	≦0.10	10~20	2,730	1,980
		160	≦0.10	8~13	2,980	1,500	190	≦0.10	10~16	2,370	1,500
Mold steel (NAK80, HPM1, P21) 38-43HRC	DH102 (JC8015)	~80	≦0.12	8~16	3,980	1,910	~100	≦0.12	10~20	3,180	1,910
		120	≦0.10	8~16	2,980	1,150	150	≦0.10	10~20	2,400	1,150
		160	≦0.10	8~13	2,580	870	190	≦0.10	10~16	2,070	870
Hardened die steel (SKD61, DAC, DHA) 42-52HRC	DH102 (JC8015)	~80	≦0.10	8~16	2,380	960	~100	≦0.10	10~20	1,920	960
		120	≦0.08	8~16	1,780	570	150	≦0.08	10~20	1,440	570
		160	—	—	—	—	190	—	—	—	—
Hardened die steel (SKD11, SLD, DC11) 55-62HRC	DH102	~80	≦0.10	8~16	1,400	450	~100	≦0.10	10~20	1,110	450
		120	≦0.08	8~16	1,040	270	150	≦0.08	10~20	840	270
		160	—	—	—	—	190	—	—	—	—
Grey & Nodular cast iron (FC, FCD) below 300HB	JC8015 (DH102)	~80	≦0.15	8~16	3,980	2,380	~100	≦0.15	10~20	3,180	2,380
		120	≦0.12	8~16	2,980	1,430	150	≦0.12	10~20	2,400	1,430
		160	≦0.10	8~13	2,580	1,010	190	≦0.10	10~16	2,070	1,010
Stainless steel (SUS304) below 250HB	JC8015 (DH102)	~80	≦0.12	8~16	4,580	3,290	~100	≦0.12	10~20	3,660	3,290
		120	≦0.10	8~16	3,440	1,980	150	≦0.10	10~20	2,730	1,980
		160	≦0.10	8~13	2,980	1,500	190	≦0.10	10~16	2,370	1,500
Titanium alloy (Ti-6Al-4V)	JC8015 (DH102)	~80	≦0.12	8~16	1,000	480	~100	≦0.12	10~20	780	480
		120	≦0.10	8~16	740	290	150	≦0.10	10~20	600	290
		160	≦0.10	8~13	640	220	190	≦0.10	10~16	510	220

Note

1. Please adjust cutting conditions according to machine rigidity or work rigidity.
2. In case of chatter occurring, recommended to reduce a_p or rpm and keep feed per tooth.
3. a_p should be reduced when using on low rigidity machine.
4. Use air blow.

QM MILL**MPM Type**

■ Recommended cutting conditions

● MPM type (YOHV insert) - Bottom finishing

4

Material	Grade	Tool dia.(mm)														
		25					30					32				
		6N					7N					8N				
		ℓ (mm)	ap (mm)	ae (mm)	n (min ⁻¹)	Vf (mm/min)	ℓ (mm)	ap (mm)	ae (mm)	n (min ⁻¹)	Vf (mm/min)	ℓ (mm)	ap (mm)	ae (mm)	n (min ⁻¹)	Vf (mm/min)
Carbon steel (S50C, S55C) below 250HB	JC8015 (DH102)	~120	≤0.12	12~25	3,180	3,820	~160	≤0.12	15~30	2,640	3,700	~160	≤0.12	16~32	2,490	3,980
		190	≤0.10	12~25	2,380	2,280	240	≤0.10	15~30	1,980	2,220	240	≤0.10	16~32	1,870	2,380
		235	≤0.06	12~20	2,070	1,740	290	≤0.06	15~24	1,700	1,670	290	≤0.06	16~26	1,620	1,800
Tool & die steel (SKD61, SKD11) below 255HB	JC8015 (DH102)	~120	≤0.12	12~25	2,930	3,160	~160	≤0.12	15~30	2,440	3,070	~160	≤0.12	16~32	2,290	3,290
		190	≤0.10	12~25	2,200	1,900	240	≤0.10	15~30	1,820	1,830	240	≤0.10	16~32	1,720	1,980
		235	≤0.06	12~20	1,900	1,440	290	≤0.06	15~24	1,580	1,390	290	≤0.06	16~26	1,490	1,500
Mold steel (HPM7, PX5, P20) 30-36 HRC	JC8015 (DH102)	~120	≤0.12	12~25	2,930	3,160	~160	≤0.12	15~30	2,440	3,070	~160	≤0.12	16~32	2,290	3,290
		190	≤0.10	12~25	2,200	1,900	240	≤0.10	15~30	1,820	1,830	240	≤0.10	16~32	1,720	1,980
		235	≤0.06	12~20	1,900	1,440	290	≤0.06	15~24	1,590	1,390	290	≤0.06	16~26	1,490	1,500
Mold steel (NAK80, HPM1, P21) 38-43HRC	DH102 (JC8015)	~120	≤0.12	12~25	2,550	1,840	~160	≤0.12	15~30	2,120	1,780	~160	≤0.12	16~32	1,990	1,910
		190	≤0.10	12~25	1,910	1,100	240	≤0.10	15~30	1,600	1,080	240	≤0.10	16~32	1,490	1,150
		235	≤0.06	12~20	1,660	840	290	≤0.06	15~24	1,380	810	290	≤0.06	16~26	1,290	870
Hardened die steel (SKD61, DAC, DHA) 42-52HRC	DH102 (JC8015)	~120	≤0.10	12~25	1,530	920	~160	≤0.10	15~30	1,280	900	~160	≤0.10	16~32	1,190	960
		190	≤0.08	12~25	1,150	550	240	≤0.08	15~30	960	540	240	≤0.08	16~32	890	570
		235	—	—	—	—	290	—	—	—	—	290	—	—	—	—
Hardened die steel (SKD11, SLD, DC11) 55-62HRC	DH102	~120	≤0.10	12~25	890	430	~160	≤0.10	15~30	740	410	~160	≤0.10	16~32	700	450
		190	≤0.08	12~25	670	260	240	≤0.08	15~30	560	250	240	≤0.08	16~32	520	270
		235	—	—	—	—	290	—	—	—	—	290	—	—	—	—
Grey & Nodular cast iron (FC, FCD) below 300HB	JC8015 (DH102)	~120	≤0.15	12~25	2,550	2,300	~160	≤0.15	15~30	2,120	2,230	~160	≤0.15	16~32	1,990	2,380
		190	≤0.12	12~25	1,910	1,380	240	≤0.12	15~30	1,600	1,340	240	≤0.12	16~32	1,490	1,430
		235	≤0.10	12~20	1,660	970	290	≤0.10	15~24	1,380	940	290	≤0.10	16~26	1,290	1,010
Stainless steel (SUS304) below 250HB	JC8015 (DH102)	~120	≤0.12	12~25	2,930	3,160	~160	≤0.12	15~30	2,440	3,070	~160	≤0.12	16~32	2,290	3,290
		190	≤0.12	12~25	2,200	1,900	240	≤0.12	15~30	1,820	1,830	240	≤0.12	16~32	1,720	1,980
		235	≤0.10	12~20	1,900	1,440	290	≤0.10	15~24	1,590	1,390	290	≤0.10	16~26	1,490	1,500
Titanium alloy (Ti-6Al-4V)	JC8015 (DH102)	~120	≤0.12	12~25	640	460	~160	≤0.12	15~30	520	440	~160	≤0.12	16~32	500	480
		190	≤0.10	12~25	480	280	240	≤0.10	15~30	400	270	240	≤0.10	16~32	370	290
		235	≤0.06	12~20	420	210	290	≤0.06	15~24	340	200	290	≤0.06	16~26	320	220

Note

1. Please adjust cutting conditions according to machine rigidity or work rigidity.
2. In case of chatter occurring, recommended to reduce ap or rpm and keep feed per tooth.
3. ap should be reduced when using on low rigidity machine.
4. Use air blow.